

COUNCIL PACKET
CITY OF RIVERSIDE COUNCIL MEETING AGENDA
RIVERSIDE CITY HALL COUNCIL CHAMBERS
60 N GREENE STREET
REGULAR MEETING
Monday, June 1, 2020 – 6:00 P.M.

NOTICE TO THE PUBLIC: This is a meeting of the City Council to conduct the regular business of the City. Every item on the agenda is an item of discussion and action if needed.

1. Call meeting to order
2. Approval of agenda
3. Consent agenda
 - a. Minutes from 5-7-2020, 5-18-2020
 - b. Expenditures for 6-1-2020
 - c. Liquor license Copper Creek Ridge
4. Updates on 4th Street Project
5. Updates on Sidewalks to School Project
6. Planned Maintenance Agreement-Cummins-Lift Stations, Water Plant, WWTP, Fire Station generators
7. Review of truck bids for replacement of city truck.
8. Review of cost for foyer wall at City Hall
9. Discussion on opening of City Hall, Parks, Playgrounds, Ballfields
10. Discussion on late fees, disconnections
11. Tree removal bid for FY21
12. Discussion on Downtown Grant Program
13. Update on ambulance service
14. Annual performance reviews, salary increases update on procedure
15. Motion to adjourn

This meeting is open to the public. However, due to recent directive from Governor Reynolds to increase social distancing, we encourage the public to submit their comments in advance. Comments can be submitted by email to admin@cityofriversideiowa.com or by phone to 319- 648-3501. Written comments may also be left in the City Hall drop box up to the start of the meeting. Members of the public who want to attend in person may be asked to make accommodations to conform to social distancing guidelines as best we can. The meeting will be recorded and can be viewed by visiting the city web site at www.riversideiowa.gov.

COUNCIL PACKET

RIVERSIDE CITY COUNCIL SPECIAL MEETING: May 7, 2020

The Riverside City Council special meeting opened at 6:00 pm in City Hall with Mayor Allen Schneider requesting roll call. Council members present were: Tom Sexton, Andy Rodgers, Edgar McGuire, Jeanine Redlinger and Lois Schneider.

Motion by Sexton to approve agenda. Second by Redlinger, passed 5-0.

Schneider moved to rescind Resolution #032320-02, purchase of ambulance. Second by McGuire, passed 5-0.

Redlinger moved to adjourn at 6:16 p.m. Second by McGuire, passed 5-0.

Full content of Council Meetings can be viewed on the City web site; riversideiowa.gov

Council Meeting – Monday, May 18th, 2020 at 6:00 p.m.

ATTEST:



Becky LaRoche; City Clerk

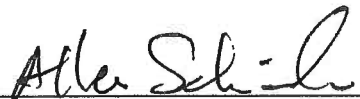

Allen Schneider; Mayor

COUNCIL PACKET

RIVERSIDE CITY COUNCIL MEETING: May 18, 2020

The Riverside City Council meeting opened at 6:00 pm in City Hall with Mayor Allen Schneider requesting roll call. Council members present were: Tom Sexton, Andy Rodgers, Edgar McGuire, Lois Schneider, and Jeanine Redlinger.

Motion by Redlinger to approve agenda. Second by McGuire, passed 5-0.

Rodgers moved to approve the minutes of May 4th 2020, expenditures, and liquor license refund for Riverside Travel Mart. Second by Schneider, passed 5-0.

Bill Stukey, PeopleServiceInc. presented April water and waste water report.

Schneider moved to approve vacation days for Administrator. Second by McGuire, passed 5-0.

Sexton moved to open Public Hearing for Budget Amendment at 6:08 pm. Second by Rodgers, passed 5-0. There were no written or oral comments. Schneider moved to close Public Hearing at 6:10 pm. Second by Rodgers, passed 5-0.

Redlinger moved to pass Resolution #051820-01 Approve adoption of City Budget Amendment for Fiscal Year July 1, 2019 to June 30, 2020. Second by Rodgers, passed 5-0.

Sexton moved to pass Resolution #051820-02, Approving Pay Request #1 for J&L Construction on the 4th Street Project in the amount of \$27,274.50 with 3.28% complete. Second by McGuire, passed 5-0.

Redlinger moved to pass Resolution #051820-03, Approving Change Order #5 for Cornerstone Excavating with the Ash/Tupelo Street Project in the amount of \$200.00 to replace curb stop at 661 Palm Street. Second by Schneider, passed 5-0.

Redlinger moved to pass Resolution #051820-04, Approving Change Order #6 for Cornerstone Excavating in the amount of \$2180.00 to raise elevation of two beehive intakes on the Ash/Tupelo Street Project. Second by Rodgers, passed 5-0.

Rodgers moved to table Resolution #051820-05 for further clarification. Second by Redlinger, passed 5-0.

Sexton moved to pass Resolution #051820-06, Approving contract with Bradley L. Hauge, CPA. Second by McGuire, passed 5-0.

McGuire moved to pass Resolution #051820-07, Approving 911 Tower Lease Site with Washington County. Second by Rodgers, passed 5-0.

McGuire moved to pass Resolution #051820-08, Approving Water Treatment Sludge Disposal Agreement with ENGIE generation North America LLC for use of Riverside's idle lagoon contingent with DNR approval of permit classification change. Second by Schneider, passed 5-0.

COUNCIL PACKET

McGuire moved to pass Resolution #051820-09, Approving pay request from American Response Vehicles in the amount of \$5000 to cancel purchase of new ambulance. Second by Schneider, passed 5-0.

Council held discussion on possible reopening of City Hall.

Mayor Schneider reported on May 16th Food Pantry in Kalona.

Council received samples of Noise Ordinance Codes. Code Committee will meet and make recommendations to Council.

Redlinger moved to enter into Closed Session per Chapter 21.5 (c) for possible litigation at 6:10 pm. Second by Rodgers, passed 5-0.

Council returned to open meeting at 7:34 pm.

Redlinger moved to adjourn at 7:39 pm.

Full content of Council Meetings can be viewed on the City web site; riversideiowa.gov

Council Meeting – Monday, June 1st, 2020 at 6:00 p.m.

ATTEST:



Becky LaRoche; City Clerk

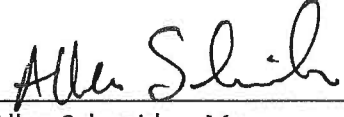

Allen Schneider; Mayor

COUNCIL PACKET

EXPENDITURES JUNE 1, 2020					
COUNCIL MEETING		BILLS			
1	ALLIANT ENERGY	PARKS	001-5-430-6371	\$	363.83
2	ALLIANT ENERGY	SEWER	610-5-815-6371	\$	1,054.38
3	ALLIANT ENERGY	CITY HALL	001-5-650-6371	\$	228.96
4	ALLIANT ENERGY	WATER	600-5-810-6371	\$	269.66
5	ALLIANT ENERGY	STREET LIGHTS	001-5-230-6371	\$	1,586.90
6	ALLIANT ENERGY	FIRE STATION	002-5-150-6330	\$	334.73
7	A-TECH	RVFD	002-5-150-6356	\$	84.00
8	BARCO	WATER/SEWER	600-5-810-6374	\$	488.37
9	BECKY LaROCHE	JUNE CELL	001-5-650-6373	\$	50.00
10	BRYAN LENZ	JUNE CELL	001-5-430-6373	\$	50.00
11	FP MAIL SOLUTIONS	POSTAGE METER	001-5-650-6508	\$	86.85
12	HENRY SCHEIN	RVFD	002-5-150-6375	\$	121.70
13	JAY STUELKE	JUNE CELL	001-5-210-6373	\$	50.00
14	JIM'S SMALL ENGINE REPAIR	RVFD	002-5-150-6356	\$	288.95
15	KIRKWOOD CC	EMS CLASSES	002-5-150-6354	\$	3,522.00
16	KOCH	COPY	001-5-650-6496	\$	693.40
17	KUM & Go FLEET	FUEL	110-5-210-6331	\$	206.18
18	KUM & Go FLEET	RVFD	002-5-150-6350	\$	208.65
19	LLOYD MCCONNELL, DAVIS	COPPER CREEK	001-5-640-6411	\$	85.00
20	MENARDS	CITY HALL	001-5-650-6310	\$	345.33
21	MENARDS	RENTAL UPPER APT.	001-5-470-6310	\$	129.77
22	MENARDS	SHOP	001-5-210-6372	\$	31.47
23	MID AMERICAN ENERGY	SHOP	001-5-210-6371	\$	41.29
24	MID AMERICAN ENERGY	RVFD	002-5-150-6371	\$	50.16
25	MID AMERICAN ENERGY	CITY HALL	001-5-650-6371	\$	21.73
26	MUNICIPLE SUPPLY	WATER/SEWER	610-5-815-6374	\$	592.60
27	PEOPLE SERVICES	JUNE SERVICE	610-5-815-6500	\$	11,214.00
28	PEOPLE SERVICES	JUNE SERVICE	600-5-800-6500	\$	11,214.00
29		TOTAL BILLS		\$	33,413.91
30	EOM PAYABLES				
31	DELTA DENTAL	JUNE BILLING	001-5-430-6150	\$	149.54
32	LINCOLN NAT'L LIFE INS	JUNE BILLING	001-5-620-6150	\$	288.55
33	MEDIACOM	RVFD	002-5-150-6332	\$	201.34
34	MEDICAOM	CITY HALL	001-5-650-6373	\$	201.34
35	TREASURER-ST OF IA	SALES TAX	600-5-810-6418	\$	77.07
36	US CELLULAR	YANCEY	001-5-650-6373	\$	48.46
37	US CELLULAR	RVFD	002-5-150-6332	\$	94.95
38	VERIZON	CELL COLLECTORS	600-5-810-6373	\$	63.54
39	WELLMARK	JUNE BILLING	001-5-620-6150	\$	4,121.12
40	WINDSTREAM	MAY BILLING	001-5-210-6373	\$	375.53
41	UMB BANK WIRE	GO BOND PAYMENT	200-5-710-6802	\$	221,500.00
42		TOTAL PAID BILLS			\$ 227,121.44
43		TOTAL EXPENDITURES		\$	260,535.35
44	TOTAL BY FUND				
45	"001"	GENERAL FUND		\$	8,949.07
46	"002"	FIRE DEPARTMENT		\$	4,906.48
47	"110"	ROAD USE FUND		\$	206.18
48	"145"	CASINO FUNDS		\$	-
	"200"	DEBT SERVICE		\$	221,500.00
49	"301"	CAPITAL PROJECTS		\$	-
50	"600"	WATER FUND		\$	12,112.64
51	"610"	SEWER FUND		\$	12,860.98
52	"670"	GARBAGE		\$	-
53		TOTAL EXPENDITURES		\$	260,535.35

COUNCIL PACKET

Becky

From: Licensing2, ABD <licensing2@iowaabd.com> on behalf of licensing@iowaabd.com
Sent: Friday, May 22, 2020 1:32 AM
To: becky@cityofriversideiowa.com
Cc: Licensing@IowaABD.com
Subject: Liquor License Submitted to Local Authority

Insurance coverage/bond certification has been completed for the following application(s). The application(s) is awaiting local authority review. After local authority approval, the application will be submitted to the Iowa Alcoholic Beverages Division for review.

License #	License Status	Business Name
LC0045571	Submitted to Local Authority	Copper Creek Ridge (1182 Commercial Drive Riverside Iowa, 52327)

Please do not respond to this email.

To check the status of your application follow these steps:

1. Click <https://elicensing.iowaabd.com>
2. Log in to your eLicensing account
3. After reading the 'Beginning April 1st' statement, click ok
4. Click the View Completed Applications link to see your status



Sales and Service

CEDAR RAPIDS IA BRANCH
 625 33RD AVE SW
 CEDAR RAPIDS, IA 52404
 Phone: 319-366-7537

PLANNED MAINTENANCE AGREEMENT

Customer Address	Customer Contact	Quote Information
CITY OF RIVERSIDE PO BOX Riverside, IA 52327	Contact: Bill Stukey Phone: 319 8003281 Fax: Cust Id: 93639	Quote Date: 20-MAY-20 Quote Expires: 20-MAY-21 Quote Num: 101359 Quoted By: Karol A Koopman Quote Term: 1 Year(s)

Site Information

1	LIFT STATION 1	21 E 1ST ST	RIVERSIDE	IA	52327
2	LIFT STATION 2	21 E 1ST ST	RIVERSIDE	IA	52327
3	LIFT STATION 3	21 E 1ST ST	RIVERSIDE	IA	52327
4	LIFT STATION 4	21 E 1ST ST	RIVERSIDE	IA	52327
5	LIFT STATION 5	21 E 1ST ST	RIVERSIDE	IA	52327
6	WATER PLANT	21 E 1ST ST	RIVERSIDE	IA	52327
7	WWTP	21 E 1ST ST	RIVERSIDE	IA	52327
8	FIRE STATION	21 E 1ST ST	RIVERSIDE	IA	52327

Site	Unit Number	Manufacturer	Model	Prod Model	Serial Number	Type
1	LIFT STATION 1	OLYMPIAN	125 KW - D125P	D125P1	NAT00599	STANDBY
2	LIFT STATION 2	OLYMPIAN	40 KW - D40P3	D40P3	NPF01766	STANDBY
3	LIFT STATION 3	OLYMPIAN	50 KW - D50P3	D50P3	NPF02488	STANDBY
4	LIFT STATION 4	CAT	C2.2	C2.2	GBE00945	STANDBY
5	LIFT STATION 5	OLYMPIAN	D125P2	D125P2	NPS02212	STANDBY
6	WATER PLANT	CAT	550KW - C15	C15	C5E00651	STANDBY
7	WWTP	CAT	626KW - C18	C18	STD00179	STANDBY
8	FIRE STATION	KATOLIGHT	50KW - SED50FI	SED50FPJ4T2	146139-0507	STANDBY

Site	Unit Number	Service Event	Qty	Sell Price	Extended Price
1	LIFT STATION 1	Inspection w/ Full Service - August 2020	1	736.62	736.62
2	LIFT STATION 2	Inspection w/ Full Service - August 2020	1	573.03	573.03
3	LIFT STATION 3	Inspection w/ Full Service - August 2020	1	539.27	539.27
4	LIFT STATION 4	Inspection w/ Full Service - August 2020	1	523.76	523.76
5	LIFT STATION 5	Inspection w/ Full Service - August 2020	1	736.62	736.62
6	WATER PLANT	Inspection w/ Full Service - August 2020	1	1,021.16	1,021.16
7	WWTP	Inspection w/ Full Service - August 2020	1	1,042.11	1,042.11
8	FIRE STATION	Inspection w/ Full Service - August 2020	1	618.61	618.61

** Quote does not include applicable taxes **

Please complete, sign, and return to:
 Karol Koopman | fax # 605-336-1748 | karol.a.koopman@cummins.com

COUNCIL PACKET

PLANNED MAINTENANCE AGREEMENT TERMS AND CONDITIONS

These Planned Maintenance Agreement Terms and Conditions, together with the Quote on the front side and the Scope of Services, are hereinafter referred to as this 'Agreement' and shall constitute the entire agreement between the customer identified in the Quote ('Customer') and Cummins Inc. ('Cummins') and supersede any previous agreement or understanding (oral or written) between the parties with respect to the subject matter of this Agreement. In the event of any inconsistency between this Agreement and any purchase order, terms and conditions or other document produced or delivered by Customer, the terms and conditions of this Agreement shall take precedence.

1. **SCOPE OF SERVICES; PERFORMANCE OF SERVICES.** Cummins shall perform the maintenance ('Services') on the equipment identified in the Quote ('Equipment') in accordance with the schedule specified in the Quote. The Services include those services defined in the 'Service Event' section of the Quote. No additional services or materials are included in this Agreement unless agreed upon by the parties in writing. Unless otherwise indicated in the Quote, Cummins will provide the labor and tools necessary to perform the Services and shall keep Customer's property free from accumulation of waste materials caused by Cummins' operations. Either party may terminate this Agreement with or without cause by providing thirty (30) days written notice to the other.
2. **CUSTOMER OBLIGATIONS.** Customer shall provide Cummins safe access to Customer's site and arrange for all related services and utilities necessary for Cummins to perform the Services. During the performance of the Services, Customer shall fully and completely secure all or any part of any facility where the Equipment is located to remove and mitigate any and all safety issues and risks, including but not limited to facility occupants, customers, invitees, or any third party and or property damage or work interruption arising out of the Services. Customer shall make all necessary arrangement to address and mitigate the consequences of any electrical service interruption which might occur during the Services. **CUSTOMER IS RESPONSIBLE FOR OPERATING AND MAINTAINING THE EQUIPMENT IN ACCORDANCE WITH THE OWNER'S MANUAL FOR THE EQUIPMENT.**
3. **PAYMENT TERMS.** Unless otherwise agreed to by the parties in writing and subject to credit approval by Cummins, payments are due thirty (30) days from the date of the invoice. If Customer does not have approved credit with Cummins, as solely determined by Cummins, payments are due in advance or at the time of supply of the Services. If payment is not received when due, in addition to any rights Cummins may have at law, Cummins may charge Customer eighteen percent (18%) interest annually on late payments, or the maximum amount allowed by law. Customer agrees to pay all Cummins' costs and expenses (including all reasonable attorneys' fees) related to Cummins' enforcement and collection of unpaid invoices, or any other enforcement of this Agreement by Cummins. Unless otherwise stated, the Quote excludes all applicable local, state, or federal sales and/or use or similar taxes which Cummins is required by applicable laws to collect from Customer and shall be stated on the invoice.
4. **DELAYS.** Any performance dates indicated in this Agreement are estimated and not guaranteed. Cummins shall not be liable for any delays in performance however occasioned, including any that result directly or indirectly from acts of Customer or causes beyond Cummins' control, including but not limited to acts of God, accidents, fire, explosions, flood, unusual weather conditions, acts of government authority, or labor disputes.
5. **WARRANTY.** Cummins shall perform the Services in a reasonable and workmanlike manner. Parts and components supplied under this Agreement are governed by the express written manufacturer's limited warranty. No other warranty for parts or components is provided under this Agreement. All Services shall be free from defects in workmanship for a period of ninety (90) days after completion of Services. In the event of a warrantable defect in workmanship of Services supplied under this Agreement ('Warrantable Defect'), Cummins' obligation shall be solely limited to correcting the Warrantable Defect. Cummins shall correct the Warrantable Defect where (i) such Warrantable Defect becomes apparent to Customer during the warranty period; (ii) Cummins receives written notice of any Warrantable Defect within thirty (30) days following discovery by Customer; and (iii) Cummins has determined that there is a Warrantable Defect. Warrantable Defects remedied under this provision shall be subject to the remaining warranty period of the original warranty of the Services. New parts supplied during the remedy of Warrantable Defects are warranted for the balance of the warranty period still available from the original warranty of such parts. The remedies set forth in this Section 5 shall not be deemed to have failed of their essential purpose so long as Cummins is willing to correct defective Services or refund the purchase price therefor.
6. **LIMITATIONS OF WARRANTIES AND LIABILITY.** THE REMEDIES PROVIDED IN THE LIMITED WARRANTY AND THIS AGREEMENT ARE THE SOLE AND EXCLUSIVE WARRANTIES AND REMEDIES PROVIDED BY CUMMINS TO THE CUSTOMER UNDER THIS AGREEMENT. EXCEPT AS SET OUT IN THE WARRANTY AND THIS AGREEMENT, AND TO THE EXTENT PERMITTED BY LAW, CUMMINS EXPRESSLY DISCLAIMS ALL OTHER REPRESENTATIONS, WARRANTIES, ENDORSEMENTS, AND CONDITIONS OF ANY KIND, EXPRESS OR IMPLIED, INCLUDING, WITHOUT LIMITATION, ANY STATUTORY OR COMMON LAW IMPLIED REPRESENTATIONS, WARRANTIES AND CONDITIONS OF FITNESS FOR A PURPOSE OR MERCHANTABILITY. NOTWITHSTANDING ANY OTHER TERM OF THIS AGREEMENT, IN NO EVENT SHALL CUMMINS, ITS OFFICERS, DIRECTORS, EMPLOYEES, OR AGENTS BE LIABLE TO CUSTOMER OR ANY THIRD PARTY FOR ANY INDIRECT, INCIDENTAL, SPECIAL, PUNITIVE, OR CONSEQUENTIAL DAMAGES OF ANY KIND (INCLUDING WITHOUT LIMITATION DOWNTIME, LOSS OF PROFIT OR REVENUE, LOSS OF DATA, LOSS OF OPPORTUNITY, DAMAGE TO GOODWILL, AND DAMAGES CAUSED BY DELAYS) IN ANY WAY RELATED TO OR ARISING FROM CUMMINS' SUPPLY OF PARTS OR SERVICES UNDER THIS AGREEMENT. IN NO EVENT SHALL CUMMINS' LIABILITY TO CUSTOMER OR ANY THIRD PARTY CLAIMING DIRECTLY THROUGH CUSTOMER OR ON CUSTOMER'S BEHALF UNDER THIS AGREEMENT EXCEED THE TOTAL COST OF PARTS AND SERVICES SUPPLIED BY CUMMINS UNDER THIS AGREEMENT. BY ACCEPTANCE OF THIS AGREEMENT, CUSTOMER ACKNOWLEDGES CUSTOMER'S SOLE REMEDY AGAINST CUMMINS FOR ANY LOSS SHALL BE THE REMEDY PROVIDED HEREIN.
7. **INDEMNITY.** Customer shall indemnify, defend and hold harmless Cummins from and against any and all claims, actions, costs, expenses, damages and liabilities, including reasonable attorneys' fees, brought against or incurred by Cummins related to or arising out of this Agreement or the Services supplied under this Agreement (collectively, the 'Claims'), where such Claims were caused or contributed to by, in whole or in part, the acts, omissions, fault or negligence of the Customer. Customer shall present any Claims covered by this indemnity to its insurance carrier unless Cummins directs that the defense will be handled by Cummins' legal counsel at Customer's expense.
8. **CONFIDENTIALITY.** Each party shall keep confidential any information received from the other that is not generally known to the public and at the time of disclosure, would reasonably be understood by the receiving party to be proprietary or confidential, whether disclosed in oral, written, visual, electronic or other form, and which the receiving party (or agents) learns in connection with this Agreement including, but not limited to: (a) business plans, strategies, sales, projects and analyses; (b) financial information, pricing, and fee structures; (c) business processes, methods and models; (d) employee and supplier information; (e) specifications; and (f) the terms and conditions of this Agreement. Each party shall take necessary steps to ensure compliance with this provision by its employees and agents.
9. **GOVERNING LAW.** This Agreement and all matters arising hereunder shall be governed by and construed in accordance with the laws of the State of Indiana without giving effect to any choice or conflict of law provision. The parties agree that the courts of the State of Indiana shall have exclusive jurisdiction to settle any dispute or claim arising in connection with this Agreement.
10. **INSURANCE.** Upon Customer's request, Cummins will provide to Customer a Certificate of Insurance evidencing Cummins' relevant insurance coverage.
11. **ASSIGNMENT.** This Agreement shall be binding on the parties and their successors and assigns. Customer shall not assign this Agreement without the prior written consent of Cummins.
12. **INTELLECTUAL PROPERTY.** Any intellectual property rights created by either party, whether independently or jointly, in the course of the performance of this Agreement or otherwise related to Cummins pre-existing intellectual property or subject matter related thereto, shall be Cummins' property. Customer agrees to assign, and does hereby assign, all right, title, and interest to such intellectual property to Cummins. Any Cummins pre-existing intellectual property shall remain Cummins' property. Nothing in this Agreement shall be deemed to have given Customer a licence or any other rights to use any of the intellectual property rights of Cummins.
13. **MISCELLANEOUS.** Cummins shall be an independent contractor with respect to the Services performed under this Agreement. All notices under this Agreement shall be in writing and be delivered personally, mailed via first class certified or registered mail, or sent by a nationally recognized express courier service to the addresses set forth in the Quote. No amendment of this Agreement shall be valid unless it is in writing and signed by the parties hereto. Failure of either party to require performance by the other party of any provision hereof shall in no way affect the right to require such performance at any time thereafter, nor shall the waiver by a party of a breach of any of the provisions hereof constitute a waiver of any succeeding breach. Any provision of this Agreement that is invalid or unenforceable shall not affect the validity or enforceability of the remaining terms hereof.
14. **ON-CALL SERVICES.** Upon Customer's request, Cummins shall provide on-call services (repair, emergency work or other) on the Equipment ('On-call Services'). Any On-call Services shall be invoiced to the Customer at the Cummins current hour rate (including traveling) and shall be governed by the terms and conditions of this Agreement.



Sales and Service

PLANNED MAINTENANCE AGREEMENT

<u>Customer Address</u>	<u>Customer Contact</u>	<u>Quote Information</u>
CITY OF RIVERSIDE PO BOX Riverside, IA 52327	Contact: Bill Stukey Phone: 319 8003281 Fax: Cust Id: 93639	Quote Date: 20-MAY-20 Quote Expires: 20-MAY-21 Quote Num: 101359 Quoted By: Karol A Koopman Quote Term: 1 Year(s)

Current Account Status: Charge - Pay upon receipt of invoice after service is performed

Based on your previous PM schedule, tentative schedule is as follows:

Annual Inspection w/ Full Service - August 2020

PO # _____ (If applicable)

This quote reflects labor during regular business hours, Monday through Friday
No additional repairs will be performed without customer's authorization.

If you have any questions, concerns or to make any changes please contact:
Will Siebels | fax # 319-366-7562 | will.c.siebels@cummins.com

Standard Agreement Amount	\$5,791.18
Proposal Total	\$5,791.18

There are additional contract terms & conditions on the reverse side of this document, including limitations of warranties and liability, which are expressly incorporated herein. Customer acknowledges that the contract terms and conditions have been read, fully understood, and accepted.

Customer Approval _____

CUMMINS INC _____

Signature: _____

Signature: _____

Date: _____

Date: _____

COUNCIL PACKET

PLANNED MAINTENANCE AGREEMENT TERMS AND CONDITIONS

These Planned Maintenance Agreement Terms and Conditions, together with the Quote on the front side and the Scope of Services, are hereinafter referred to as this 'Agreement' and shall constitute the entire agreement between the customer identified in the Quote ('Customer') and Cummins Inc. ('Cummins') and supersede any previous agreement or understanding (oral or written) between the parties with respect to the subject matter of this Agreement. In the event of any inconsistency between this Agreement and any purchase order, terms and conditions or other document produced or delivered by Customer, the terms and conditions of this Agreement shall take precedence.

1. **SCOPE OF SERVICES; PERFORMANCE OF SERVICES.** Cummins shall perform the maintenance ('Services') on the equipment identified in the Quote ('Equipment') in accordance with the schedule specified in the Quote. The Services include those services defined in the 'Service Event' section of the Quote. No additional services or materials are included in this Agreement unless agreed upon by the parties in writing. Unless otherwise indicated in the Quote, Cummins will provide the labor and tools necessary to perform the Services and shall keep Customer's property free from accumulation of waste materials caused by Cummins' operations. Either party may terminate this Agreement with or without cause by providing thirty (30) days written notice to the other.
2. **CUSTOMER OBLIGATIONS.** Customer shall provide Cummins safe access to Customer's site and arrange for all related services and utilities necessary for Cummins to perform the Services. During the performance of the Services, Customer shall fully and completely secure all or any part of any facility where the Equipment is located to remove and mitigate any and all safety issues and risks, including but not limited to facility occupants, customers, invitees, or any third party and or property damage or work interruption arising out of the Services. Customer shall make all necessary arrangement to address and mitigate the consequences of any electrical service interruption which might occur during the Services. **CUSTOMER IS RESPONSIBLE FOR OPERATING AND MAINTAINING THE EQUIPMENT IN ACCORDANCE WITH THE OWNER'S MANUAL FOR THE EQUIPMENT.**
3. **PAYMENT TERMS.** Unless otherwise agreed to by the parties in writing and subject to credit approval by Cummins, payments are due thirty (30) days from the date of the invoice. If Customer does not have approved credit with Cummins, as solely determined by Cummins, payments are due in advance or at the time of supply of the Services. If payment is not received when due, in addition to any rights Cummins may have at law, Cummins may charge Customer eighteen percent (18%) interest annually on late payments, or the maximum amount allowed by law. Customer agrees to pay all Cummins' costs and expenses (including all reasonable attorneys' fees) related to Cummins' enforcement and collection of unpaid invoices, or any other enforcement of this Agreement by Cummins. Unless otherwise stated, the Quote excludes all applicable local, state, or federal sales and/or use or similar taxes which Cummins is required by applicable laws to collect from Customer and shall be stated on the invoice.
4. **DELAYS.** Any performance dates indicated in this Agreement are estimated and not guaranteed. Cummins shall not be liable for any delays in performance however occasioned, including any that result directly or indirectly from acts of Customer or causes beyond Cummins' control, including but not limited to acts of God, accidents, fire, explosions, flood, unusual weather conditions, acts of government authority, or labor disputes.
5. **WARRANTY.** Cummins shall perform the Services in a reasonable and workmanlike manner. Parts and components supplied under this Agreement are governed by the express written manufacturer's limited warranty. No other warranty for parts or components is provided under this Agreement. All Services shall be free from defects in workmanship for a period of ninety (90) days after completion of Services. In the event of a warrantable defect in workmanship of Services supplied under this Agreement ('Warrantable Defect'), Cummins' obligation shall be solely limited to correcting the Warrantable Defect. Cummins shall correct the Warrantable Defect where (i) such Warrantable Defect becomes apparent to Customer during the warranty period; (ii) Cummins receives written notice of any Warrantable Defect within thirty (30) days following discovery by Customer; and (iii) Cummins has determined that there is a Warrantable Defect. Warrantable Defects remedied under this provision shall be subject to the remaining warranty period of the original warranty of the Services. New parts supplied during the remedy of Warrantable Defects are warranted for the balance of the warranty period still available from the original warranty of such parts. The remedies set forth in this Section 5 shall not be deemed to have failed of their essential purpose so long as Cummins is willing to correct defective Services or refund the purchase price therefor.
6. **LIMITATIONS OF WARRANTIES AND LIABILITY.** THE REMEDIES PROVIDED IN THE LIMITED WARRANTY AND THIS AGREEMENT ARE THE SOLE AND EXCLUSIVE WARRANTIES AND REMEDIES PROVIDED BY CUMMINS TO THE CUSTOMER UNDER THIS AGREEMENT. EXCEPT AS SET OUT IN THE WARRANTY AND THIS AGREEMENT, AND TO THE EXTENT PERMITTED BY LAW, CUMMINS EXPRESSLY DISCLAIMS ALL OTHER REPRESENTATIONS, WARRANTIES, ENDORSEMENTS, AND CONDITIONS OF ANY KIND, EXPRESS OR IMPLIED, INCLUDING, WITHOUT LIMITATION, ANY STATUTORY OR COMMON LAW IMPLIED REPRESENTATIONS, WARRANTIES AND CONDITIONS OF FITNESS FOR A PURPOSE OR MERCHANTABILITY. NOTWITHSTANDING ANY OTHER TERM OF THIS AGREEMENT, IN NO EVENT SHALL CUMMINS, ITS OFFICERS, DIRECTORS, EMPLOYEES, OR AGENTS BE LIABLE TO CUSTOMER OR ANY THIRD PARTY FOR ANY INDIRECT, INCIDENTAL, SPECIAL, PUNITIVE, OR CONSEQUENTIAL DAMAGES OF ANY KIND (INCLUDING WITHOUT LIMITATION DOWNTIME, LOSS OF PROFIT OR REVENUE, LOSS OF DATA, LOSS OF OPPORTUNITY, DAMAGE TO GOODWILL, AND DAMAGES CAUSED BY DELAYS) IN ANY WAY RELATED TO OR ARISING FROM CUMMINS' SUPPLY OF PARTS OR SERVICES UNDER THIS AGREEMENT. IN NO EVENT SHALL CUMMINS' LIABILITY TO CUSTOMER OR ANY THIRD PARTY CLAIMING DIRECTLY THROUGH CUSTOMER OR ON CUSTOMER'S BEHALF UNDER THIS AGREEMENT EXCEED THE TOTAL COST OF PARTS AND SERVICES SUPPLIED BY CUMMINS UNDER THIS AGREEMENT. BY ACCEPTANCE OF THIS AGREEMENT, CUSTOMER ACKNOWLEDGES CUSTOMER'S SOLE REMEDY AGAINST CUMMINS FOR ANY LOSS SHALL BE THE REMEDY PROVIDED HEREIN.
7. **INDEMNITY.** Customer shall indemnify, defend and hold harmless Cummins from and against any and all claims, actions, costs, expenses, damages and liabilities, including reasonable attorneys' fees, brought against or incurred by Cummins related to or arising out of this Agreement or the Services supplied under this Agreement (collectively, the 'Claims'), where such Claims were caused or contributed to by, in whole or in part, the acts, omissions, fault or negligence of the Customer. Customer shall present any Claims covered by this indemnity to its insurance carrier unless Cummins directs that the defense will be handled by Cummins' legal counsel at Customer's expense.
8. **CONFIDENTIALITY.** Each party shall keep confidential any information received from the other that is not generally known to the public and at the time of disclosure, would reasonably be understood by the receiving party to be proprietary or confidential, whether disclosed in oral, written, visual, electronic or other form, and which the receiving party (or agents) learns in connection with this Agreement including, but not limited to: (a) business plans, strategies, sales, projects and analyses; (b) financial information, pricing, and fee structures; (c) business processes, methods and models; (d) employee and supplier information; (e) specifications; and (f) the terms and conditions of this Agreement. Each party shall take necessary steps to ensure compliance with this provision by its employees and agents.
9. **GOVERNING LAW.** This Agreement and all matters arising hereunder shall be governed by and construed in accordance with the laws of the State of Indiana without giving effect to any choice or conflict of law provision. The parties agree that the courts of the State of Indiana shall have exclusive jurisdiction to settle any dispute or claim arising in connection with this Agreement.
10. **INSURANCE.** Upon Customer's request, Cummins will provide to Customer a Certificate of Insurance evidencing Cummins' relevant insurance coverage.
11. **ASSIGNMENT.** This Agreement shall be binding on the parties and their successors and assigns. Customer shall not assign this Agreement without the prior written consent of Cummins.
12. **INTELLECTUAL PROPERTY.** Any intellectual property rights created by either party, whether independently or jointly, in the course of the performance of this Agreement or otherwise related to Cummins pre-existing intellectual property or subject matter related thereto, shall be Cummins' property. Customer agrees to assign, and does hereby assign, all right, title, and interest to such intellectual property to Cummins. Any Cummins pre-existing intellectual property shall remain Cummins' property. Nothing in this Agreement shall be deemed to have given Customer a licence or any other rights to use any of the intellectual property rights of Cummins.
13. **MISCELLANEOUS.** Cummins shall be an independent contractor with respect to the Services performed under this Agreement. All notices under this Agreement shall be in writing and be delivered personally, mailed via first class certified or registered mail, or sent by a nationally recognized express courier service to the addresses set forth in the Quote. No amendment of this Agreement shall be valid unless it is in writing and signed by the parties hereto. Failure of either party to require performance by the other party of any provision hereof shall in no way affect the right to require such performance at any time thereafter, nor shall the waiver by a party of a breach of any of the provisions hereof constitute a waiver of any succeeding breach. Any provision of this Agreement that is invalid or unenforceable shall not affect the validity or enforceability of the remaining terms hereof.
14. **ON-CALL SERVICES.** Upon Customer's request, Cummins shall provide on-call services (repair, emergency work or other) on the Equipment ('On-call Services'). Any On-call Services shall be invoiced to the Customer at the Cummins current hour rate (including traveling) and shall be governed by the terms and conditions of this Agreement.

COUNCIL PACKET

City Admin

From: Bill Stukey <BStukey@peopleservice.com>
Sent: Wednesday, May 27, 2020 10:24 AM
To: 'City Admin'; 'becky@cityofriversideiowa.com'
Subject: FW: City of Riverside - Generator Planned Maintenance - 2020
Attachments: CITY_OF_RIVERSIDE.pdf

Add this to one of the council packets. This is our generator maintenance agreement with Cummins. Looks like not much has changed.

Thanks,
Bill

From: Karol A Koopman <karol.a.koopman@cummins.com>
Sent: Wednesday, May 20, 2020 4:37 PM
To: Bill Stukey <BStukey@peopleservice.com>
Subject: City of Riverside - Generator Planned Maintenance - 2020

Bill:

My name is Karol Koopman, PM Inside Sales for Cummins Sales & Service reaching out on behalf of Will Siebels regarding the renewal of your generator Planned Maintenance Agreement (PMA). Attached you will find your renewal quote which includes the equipment currently maintained under your planned maintenance program with Cummins Sales & Service.

Please sign and return the attached quote to ensure that there are no delays with scheduling. Should you have any questions or updates to your equipment, scope of service or contact information, please feel free to contact me.

Thank you for your continued business!
Karol Koopman
Planned Maintenance Inside Sales

Cummins Sales & Service
Des Moines | Cedar Rapids | Rock Island | Fargo
Sioux Falls | Grand Forks | Omaha | Kearney

Phone: 605-977-8406
Fax: 605-336-1748
karol.a.koopman@cummins.com
centralregionpm@cummins.com

NOTICE: This e-mail message (including any file attachment) is intended only for the use of the individual or entity to which it is addressed, and may contain information that is privileged and/or confidential. If you are not the intended recipient, any dissemination, distribution or copying of this communication is strictly prohibited. If you received this

COUNCIL PACKET

communication in error, please notify us immediately by reply e-mail and delete or destroy all copies of this message and any file attachment. Thank you!

COUNCIL PACKET

City Admin

From: Clyde Guillaume <cguillaume@deeryic.com>
Sent: Thursday, May 28, 2020 11:43 AM
To: admin@cityofriversideiowa.com
Subject: Trade Value 06 Chevy Silverado 3500

Jay/Brian,
Trade value for your truck, 06 Chevy Silverado 3500 with plow would be \$10,000.

Let me know if you have any questions.
Thanks, Clyde

Clyde Guillaume
Commercial Sales Manager
Deery Brothers CDJR of IC
P: 319-471-4564
C: 319-325-4950

COUNCIL PACKET

FY21 Truck Bid Tabulations

Vendor	Truck	Lights/Tool boxes	Plow	Running Boards
Truck Equipment Inc-DSM		\$ 4,220.00	\$ 6,578.28	
Future Line-Cedar Rapids			\$ 7,668.49	
Midwest Frame-Iowa City		\$ 4,220.00	\$ 6,578.28	
Capper-Washington	\$ 38,177.00			
2020 Dodge				
Deery-Iowa City-2020 Dodge	\$ 39,553.00			
Deery-Iowa City-2020 Ford	\$ 40,000.00			
Whele-West Liberty-2020 Chevy	\$ 40,988.21			
On-line				\$ 415.11
Total				\$ 49,390.39

*\$ 8,000.00 Allowance for
2006 3500 against original
bid prices
for Capper Street*

DEER CHRYSLER DODGE JEEP RAM, INC.
 E WASHINGTON ST.
 WASHINGTON, IA 523532170

Configuration Preview

Attn: Bryan 5/22/20
From: Jeremy 1 Page

Printed: 2020-05-22 10:31 AM
 Order Ship Date:

VIN:
 VON:

Quantity: 1
 Status: BA - Pending order
 FAN 1: 0135B City of Riverside IL
 FAN 2:
 Client Code:
 Bid Number:
 PO Number:

To: DEER CHRYSLER DODGE JEEP RAM, INC.
 5) E WASHINGTON ST.
 WASHINGTON, IA 523532170

Ship to:
 GAPPER CHRYSLER DODGE JEEP RAM, INC. (60808)
 1738 E WASHINGTON ST.
 WASHINGTON, IA 523532170

2020 2500 TRADESMAN REG CAB 4X4 (140 in WB 8FT 0 IN BOX) (DJ7L62)

Code	Description	MSRP(USD)	FW
DJ7L62	2500 TRADESMAN REG CAB 4X4 (140 in WB 8FT 0 IN BOX)	36,645	
2HA	Customer Preferred Package 2HA	0	
ETL	8.7L I6 Cummins Turbo Diesel Engine	9,100	
DG7	8-Spd Automatic 68RFE Transmission	0	
PW7	Bright White Clear Coat	0	
APA	Monotone Paint	0	
*TX	HD Vinyl 40/20/40 Split Bench Seat	0	
-X8	Black/Diesel Gray	0	
A61	Tradesmen Level 1 Equipment Group	895	
XAG	ParkSense FT/RR Park Assist System	395	
AMP	Chrome Appearance Group	1,095	15
AD2	Snow Chief Group	845	
GFA	Rear Window Defroster	195	
4DH	Prepaid Holdback	0	
XKS	Upfitter Electronic Module (VSIIM)	345	
4ES	Delivery Allowance Credit	0	
XMF	Spray In Bedliner	565	
MAF	Fleet Purchase Incentive	0	
XHC	Trailer Brake Control	295	
JKV	115V Auxiliary Power Outlet	150	
LNU	Front Fog Lamps	195	
XAN	Blind Spot and Cross Path Detection	695	
5N6	Easy Order	0	
4FM	Fleet Option Editor	0	
4FT	Fleet Setup Order	0	
161	Zone 51-Chicago	0	
4EA	Sold Vehicle	0	
4FA	Special Bid-Ineligible For Incentive	0	
TB0061	Government Incentives	0	
YGA	5.5 Additional Gallons of Diesel	1,695	

38,177

Total Price: 58,110

PSP Month/Week: 99
 Build Priority: 99
 Total Price: 58,110
38,177

This is not an invoice. The prices and equipment shown on this priced order confirmation are tentative and subject to change or revision without prior notice. No claims against the content listed or prices quoted will be accepted. Refer to the vehicle invoice for content and pricing. Orders are accepted only when the vehicle is shipped by the factory.



Preview Order R100 - F2B 4x4 Reg Cab SRW: Order Summary Time of Preview: 05/11/2020 12:00:53

Dealership Name: Deery Brothers Ford of Iowa City

Sales Code : F41784

Dealer Rep.	w-spurr1	Type	Stock	Vehicle Line	Superduty Chassis Cab	Order Code	R100
Customer Name		Priority Code	80	Model Year	2020	Price Level	040

DESCRIPTION	MSRP	DESCRIPTION	MSRP
F250 4X4 STYLESIDE PICKUP/142	\$36825	ENGINE BLOCK HEATER	\$100
142 INCH WHEELBASE	\$0	50 STATE EMISSIONS	\$0
OXFORD WHITE	\$0	110V/400W OUTLET	\$175
VINYL 40/20/40 SEATS	\$0	SNOW PLOW PACKAGE	\$250
MEDIUM EARTH GRAY	\$0	SPARE TIRE AND WHEEL	\$0
PREFERRED EQUIPMENT PKG.600A	\$0	TRAILER BRAKE CONTROLLER	\$270
.XL TRIM	\$0	TELESCPNG TT MIRR-POWR/HTD	\$0
.AIR CONDITIONING -- CFC FREE	\$0	ROOF CLEARANCE LIGHTS	\$95
.AM/FM STEREO MP3/CLK	\$0	JACK	\$0
6.7L POWER STROKE V8 DIESEL	\$10495	UPFITTER SWITCHES	\$165
10-SPEED AUTOMATIC	\$0	332 AMP ALTERNATOR	\$0
LT245/75R17E BSW ALL-TERRAIN	\$165	EXTERIOR BACKUP ALARM	\$140
3.31 ELECTRONIC-LOCKING AXLE	\$390	LED WARNING STROBE - AMBER	\$675
POWER EQUIPMENT GROUP	\$915	XL VALUE PACKAGE	\$395
JOB #2 ORDER	\$0	.CRUISE CONTROL	\$0
TRAILER TOWING PACKAGE	\$0	FUEL CHARGE	\$0
XL DECOR PACKAGE	\$0	PRICED DORA	\$0
10000# GVWR PACKAGE	\$0	DESTINATION & DELIVERY	\$1695
TOTAL BASE AND OPTIONS			MSRP \$52750
DISCOUNTS			NA
TOTAL	<i>\$40,000</i>		\$52750

Customer Name:
 Customer Address:

Customer Email:
 Customer Phone:

COUNCIL PACKET

DEERY BROTHERS MOTORS OF IOWA CITY, IN
 651 HIGHWAY 1 W
 IOWA CITY, IA 522464219

Configuration Preview

Date Printed: 2020-05-11 11:36 AM
 Estimated Ship Date:

VIN:
 VON:

Quantity: 1
 Status: BA - Pending order
 FAN 1: 013SB City of Riverside Iowa
 FAN 2:
 Client Code:
 Bid Number: TB0061
 PO Number:

Sold to:
 DEERY BROTHERS MOTORS OF IOWA CITY,
 INC. (45512)
 651 HIGHWAY 1 W
 IOWA CITY, IA 522464219

Ship to:
 DEERY BROTHERS MOTORS OF IOWA CITY, INC. (45512)
 651 HIGHWAY 1 W
 IOWA CITY, IA 522464219

Vehicle:

2020 2500 TRADESMAN REG CAB 4X4 (140 in WB 8FT 0 IN box) (DJ7L62)

	Sales Code	Description	MSRP(USD)
Model:	DJ7L62	2500 TRADESMAN REG CAB 4X4 (140 in WB 8FT 0 IN box)	36,645
Package:	2HA	Customer Preferred Package 2HA	0
	ETL	6.7L I6 Cummins Turbo Diesel Engine	9,100
	DG7	6-Spd Automatic 68RFE Transmission	0
Paint/Seat/Trim:	PW7	Bright White Clear Coat	0
	APA	Monotone Paint	0
	*TX	HD Vinyl 40/20/40 Split Bench Seat	0
	-X8	Black/Diesel Gray	0
Options:	LNJ	Front Fog Lamps	195
	XHC	Trailer Brake Control	295 ✓
	XMF	Spray in Bedliner	565 ✓
	XXS	Upfitter Electronic Module (VSIM)	345
	GFA	Rear Window Defroster	195
	4DH	Prepaid Holdback	0
	DK3	Elec Shift-On-The-Fly Transfer Case	295
	4ES	Delivery Allowance Credit	0
	AD2	Snow Chief Group	845
	MAF	Fleet Purchase Incentive	0
	AMP	Chrome Appearance Group	1,095 ✓
	XAG	ParkSense FT/RR Park Assist System	395
	A61	Tradesman Level 1 Equipment Group	895 ✓
	XAN	Blind Spot and Cross Path Detection	695 ✓
	5N6	Easy Order	0
	4FM	Fleet Option Editor	0
	4FT	Fleet Sales Order	0
	151	Zone 51-Chicago	0
	4EA	Sold Vehicle	0
	Non Equipment:	4FA	Special Bid-Ineligible For Incentive
Bid Number:	TB0061	Government Incentives	0
Discounts:	YG4	5.5 Additional Gallons of Diesel	0
Destination Fees:			1,695

Total Price: 53,255

Order Type: Fleet
 Scheduling Priority: 1-Sold Order

PSP Month/Week:
 Build Priority: 99

\$39,553

Note: This is not an invoice. The prices and equipment shown on this priced order confirmation are tentative and subject to change or correction without prior notice. No claims against the content listed or prices quoted will be accepted. Refer to the vehicle invoice for final vehicle content and pricing. Orders are accepted only when the vehicle is shipped by the factory.

whele



Vehicle: [Fleet] 2020 Chevrolet Silverado 2500HD (CK20903) 4WD Reg Cab 142" Work Truck (✓
Complete)

Standard Equipment

Package

Trailer Package includes trailer hitch, 7-pin connector and (CTT) Hitch Guidance (Deleted when (ZW9) pickup bed delete is ordered.)

Mechanical

Engine, 6.6L V8 with Direct Injection and Variable Valve Timing, gasoline, (401 hp [299 kW] @ 5200 rpm, 464 lb-ft of torque [629 N-m] @ 4000 rpm) (STD)

Transmission, 6-speed automatic, heavy-duty (STD) (Requires (L8T) 6.6L V8 gas engine.)

Rear axle, 3.73 ratio (Requires (L8T) 6.6L V8 gas engine. Not available with (L5P) Duramax 6.6L Turbo-Diesel V8 engine.)

Durabed, pickup bed (STD)

GVWR, 10,250 lbs. (4649 kg) (STD) (Included and only available with CC20753 model and (L8T) 6.6L V8 gas engine with 18" or 20" wheels or CK20903 model and (L8T) 6.6L V8 gas engine with 17" wheels.)

Air filter, high-capacity

Air filtration monitoring

Transfer case, two-speed electronic shift with push button controls (Requires 4WD models.)

Differential, heavy-duty locking rear

Four wheel drive

Cooling, external engine oil cooler

Cooling, auxiliary external transmission oil cooler

Battery, heavy-duty 720 cold-cranking amps/80 Amp-hr maintenance-free with rundown protection and retained accessory power (Included and only available with (L8T) 6.6L V8 gas engine.)

Alternator, 170 amps (Requires (L8T) 6.6L V8 gas engine.)

Frame, fully-boxed, hydroformed front section and a fully-boxed stamped rear section

Recovery hooks, front, frame-mounted, Black (Not included when (VQY) Chrome recovery hooks, LPO is ordered.)

Suspension Package

Steering, Recirculating Ball with smart flow power steering system

Brakes, 4-wheel antilock, 4-wheel disc with DURALIFE rotors

Brake lining wear indicator

Capless Fuel Fill (Requires (L8T) 6.6L V8 gas engine. Not available with (ZW9) pickup bed delete.)

Exterior

Wheels, 17" (43.2 cm) painted steel, Silver (STD)

This document contains information considered Confidential between GM and its Clients uniquely. The information provided is not intended for public disclosure. Prices, specifications, and availability are subject to change without notice, and do not include certain fees, taxes and charges that may be required by law or vary by manufacturer or region. Performance figures are guidelines only, and actual performance may vary. Photos may not represent actual vehicles or exact configurations. Content based on report preparer's input is subject to the accuracy of the input provided.

Data Version: 10973. Data Updated: May 13, 2020 10:06:00 PM PDT.

COUNCIL PACKET



Vehicle: [Fleet] 2020 Chevrolet Silverado 2500HD (CK20903) 4WD Reg Cab 142" Work Truck (Complete) (✓)

Exterior

Tires, LT245/75R17E all-season, blackwall (STD)

Tire, spare LT245/75R17E all-season, blackwall (STD) (Included and only available with (QHQ) LT245/75R17E all-season, blackwall tires with (E63) Durabed, pickup bed. Available to order when (ZW9) pickup bed delete and (QHQ) LT245/75R17E all-season, blackwall tires are ordered)

Tire carrier lock keyed cylinder lock that utilizes same key as ignition and door (Deleted with (ZW9) pickup bed delete.)

Bumpers, front, Black

Bumpers, rear, Black

CornerStep, rear bumper

BedStep, Black integrated on forward portion of bed on driver and passenger side (Deleted when (ZW9) pickup bed delete is ordered.)

Moldings, beltline, Black

Cargo tie downs (12), fixed rated at 500 lbs per corner (Deleted with (ZW9) pickup bed delete.)

Grille (Front grille bar with "CHEVROLET" molded in Black, includes Black mesh inserts with small Gold bowtie emblem.)

Headlamps, halogen reflector with halogen Daytime Running Lamps

Taillamps with incandescent tail, stop and reverse lights

Lamps, cargo area, cab mounted integrated with center high mount stop lamp, with switch in bank on left side of steering wheel.

Mirrors, outside high-visibility vertical trailering lower convex mirrors, manual-folding/extending (extends 3.31" [84.25mm]), molded in Black

Mirror caps, Black

Glass, solar absorbing, tinted

Tailgate and bed rail protection cap, top

Tailgate, locking, utilizes same key as ignition and door (Upgraded to (QT5) EZ Lift power lock and release tailgate when (ZLQ) WT Fleet Convenience Package or (PCV) WT Convenience Package is ordered. Not available with (ZW9) pickup bed delete.)

Tailgate, gate function manual, no EZ Lift (Deleted with (ZW9) pickup bed delete.)

Door handles, Black grained

Entertainment

Audio system, Chevrolet Infotainment 3 system 7" diagonal color touchscreen, AM/FM stereo. Additional features for compatible phones include: Bluetooth audio streaming for 2 active devices, voice command pass-through to phone, Apple CarPlay and Android Auto capable. (STD)

Audio system feature, 2-speakers (Requires Regular Cab model.)

This document contains information considered Confidential between GM and its Clients uniquely. The information provided is not intended for public disclosure. Prices, specifications, and availability are subject to change without notice, and do not include certain fees, taxes and charges that may be required by law or vary by manufacturer or region. Performance figures are guidelines only, and actual performance may vary. Photos may not represent actual vehicles or exact configurations. Content based on report preparer's input is subject to the accuracy of the input provided.

Data Version: 10973. Data Updated: May 13, 2020 10:06:00 PM PDT.

COUNCIL PACKET



Vehicle: [Fleet] 2020 Chevrolet Silverado 2500HD (CK20903) 4WD Reg Cab 142" Work Truck (Complete)

Entertainment

Bluetooth for phone connectivity to vehicle infotainment system

Interior

Seats, front 40/20/40 split-bench (no storage) (STD)

Vinyl seat trim

Seat adjuster, driver 4-way manual

Seat adjuster, passenger 4-way manual

Floor covering, rubberized-vinyl (Not available with LPO floor liners.)

Steering wheel, urethane

Steering column, Tilt-Wheel, manual with wheel locking security feature

Instrument cluster 6-gauge cluster featuring speedometer, fuel level, engine temperature, tachometer, voltage and oil pressure

Driver Information Center, 3.5" diagonal monochromatic display

Exterior Temperature Display located in radio display

Windows, manual (Requires Regular Cab model.)

Door locks, manual (Requires Regular Cab model.)

USB port, located on instrument panel

Power outlet, front auxiliary, 12-volt

Air conditioning, single-zone

Mirror, inside rearview, manual tilt

Assist handles front A-pillar mounted for driver and passenger, rear B-pillar mounted

Safety-Mechanical

StabiliTrak stability control system with Proactive Roll Avoidance and traction control, includes electronic trailer sway control and hill start assist

Safety-Exterior

Daytime Running Lamps with automatic exterior lamp control

Safety-Interior

Airbags, Dual-stage frontal airbags for driver and front outboard passenger; Seat-mounted side-impact airbags for driver and front outboard passenger; Head-curtain airbags for front and rear outboard seating positions; Includes front outboard Passenger Sensing System for frontal outboard passenger airbag (Always use seat belts and child restraints. Children are safer when properly secured in a rear seat in the appropriate child restraint. See the Owner's Manual for more information.)

Rear Vision Camera (Deleted with (ZW9) pickup bed delete.)

This document contains information considered Confidential between GM and its Clients uniquely. The information provided is not intended for public disclosure. Prices, specifications, and availability are subject to change without notice, and do not include certain fees, taxes and charges that may be required by law or vary by manufacturer or region. Performance figures are guidelines only, and actual performance may vary. Photos may not represent actual vehicles or exact configurations. Content based on report preparer's input is subject to the accuracy of the input provided.

Data Version: 10973. Data Updated: May 13, 2020 10:06:00 PM PDT.

COUNCIL PACKET



Vehicle: [Fleet] 2020 Chevrolet Silverado 2500HD (CK20903) 4WD Reg Cab 142" Work Truck (✓
Complete)

Safety-Interior

Hitch Guidance (Deleted with (ZW9) pickup bed delete.)

Teen Driver a configurable feature that lets you activate customizable vehicle settings associated with a key fob, to help encourage safe driving behavior. It can limit certain available vehicle features, and it prevents certain safety systems from being turned off. An in-vehicle report card gives you information on driving habits and helps you to continue to coach your new driver

Tire Pressure Monitoring System with Tire Fill Alert (does not apply to spare tire)

Processing-Other

Trailer Information Label provides max trailer ratings for tongue weight, conventional, gooseneck and 5th wheel trailering (Not available with (ZW9) pickup bed delete.)

WARRANTY

Warranty Note: <<< Preliminary 2020 Warranty Note >>>

Basic Years: 3

Basic Miles/km: 36,000

Drivetrain Years: 5

Drivetrain Miles/km: 60,000

Drivetrain Note: HD Duramax Diesel: 5 Years/100,000 Miles; Qualified Fleet Purchases: 5 Years/100,000 Miles

Corrosion Years (Rust-Through): 6

Corrosion Years: 3

Corrosion Miles/km (Rust-Through): 100,000

Corrosion Miles/km: 36,000

Roadside Assistance Years: 5

Roadside Assistance Miles/km: 60,000

Roadside Assistance Note: HD Duramax Diesel: 5 Years/100,000 Miles; Qualified Fleet Purchases: 5 Years/100,000 Miles

Maintenance Note: 1 Year/1 Visit

This document contains information considered Confidential between GM and its Clients uniquely. The information provided is not intended for public disclosure. Prices, specifications, and availability are subject to change without notice, and do not include certain fees, taxes and charges that may be required by law or vary by manufacturer or region. Performance figures are guidelines only, and actual performance may vary. Photos may not represent actual vehicles or exact configurations. Content based on report preparer's input is subject to the accuracy of the input provided.

Data Version: 10973. Data Updated: May 13, 2020 10:06:00 PM PDT.

COUNCIL PACKET



Vehicle: [Fleet] 2020 Chevrolet Silverado 2500HD (CK20903) 4WD Reg Cab 142" Work Truck (Complete) ✔

Window Sticker

SUMMARY

[Fleet] 2020 Chevrolet Silverado 2500HD (CK20903) 4WD Reg Cab 142" Work Truck MSRP:\$37,400.00

Interior:Jet Black, Vinyl seat trim

Exterior 1:Summit White

Exterior 2:No color has been selected.

Engine, Duramax 6.6L Turbo-Diesel V8

Transmission, Allison 10-speed automatic

OPTIONS

CODE	MODEL	MSRP
CK20903	[Fleet] 2020 Chevrolet Silverado 2500HD (CK20903) 4WD Reg Cab 142" Work Truck	\$37,400.00
OPTIONS		
1WT	Work Truck Preferred Equipment Group	\$0.00
A52	Seats, front 40/20/40 split-bench (no storage)	\$0.00
AED	Window, power front, passenger express down	Inc.
AQQ	Remote Keyless Entry	Inc.
AU3	Door locks, power	Inc.
AXG	Window, power front, drivers express up/down	Inc.
BHP	Winter Grille Cover	Inc.
DD8	Mirror, inside rearview auto-dimming	Inc.
DWI	Mirrors, outside power-adjustable vertical trailering with heated and auto-dimming upper glass	\$720.00
E63	Durabed, pickup bed	\$0.00
FE9	Emissions, Federal requirements	\$0.00
GAZ	Summit White	\$0.00
GU6	Rear axle, 3.42 ratio	Inc.
H2G	Jet Black, Vinyl seat trim	\$0.00
IOR	Audio system, Chevrolet Infotainment 3 system	\$0.00
JFM	GVWR, 10,900 lbs. (4944 kg)	Inc.
JL1	Trailer brake controller, integrated	\$275.00

This document contains information considered Confidential between GM and its Clients uniquely. The information provided is not intended for public disclosure. Prices, specifications, and availability are subject to change without notice, and do not include certain fees, taxes and charges that may be required by law or vary by manufacturer or region. Performance figures are guidelines only, and actual performance may vary. Photos may not represent actual vehicles or exact configurations. Content based on report preparer's input is subject to the accuracy of the input provided.

Data Version: 10973. Data Updated: May 13, 2020 10:06:00 PM PDT.

COUNCIL PACKET



Vehicle: [Fleet] 2020 Chevrolet Silverado 2500HD (CK20903) 4WD Reg Cab 142" Work Truck (Complete) (✓)

K05	Engine block heater	Inc.	
K34	Cruise control, electronic	Inc.	
K40	Exhaust brake	Inc.	
KW5	Alternator, 220 amps	Inc.	
L5P	Engine, Duramax 6.6L Turbo-Diesel V8		\$9,890.00
MGM	Transmission, Allison 10-speed automatic	Inc.	
NZZ	Skid Plates	Inc.	
PYN	Wheels, 17" (43.2 cm) painted steel, Silver		\$0.00
QT5	Tailgate, gate function manual with EZ Lift	Inc.	
QXT	Tires, LT265/70R17E all-terrain, blackwall		\$200.00
VYU	Snow Plow Prep/Camper Package		\$150.00
ZLQ	WT Fleet Convenience Package		\$1,190.00
ZXT	Tire, spare LT265/70R17E all-terrain, blackwall		\$0.00
—	Battery, heavy-duty dual 730 cold-cranking amps/70 Amp-hr	Inc.	
—	Capped Fuel Fill	Inc.	

SUBTOTAL	\$49,825.00
Adjustments Total	\$0.00
Destination Charge	\$1,595.00
TOTAL PRICE	\$51,420.00

FUEL ECONOMY

Est City:N/A
 Est Highway:N/A
 Est Highway Cruising Range:N/A

*40,980.21
 plus Fees*

This document contains information considered Confidential between GM and its Clients uniquely. The information provided is not intended for public disclosure. Prices, specifications, and availability are subject to change without notice, and do not include certain fees, taxes and charges that may be required by law or vary by manufacturer or region. Performance figures are guidelines only, and actual performance may vary. Photos may not represent actual vehicles or exact configurations. Content based on report preparer's input is subject to the accuracy of the input provided.

Data Version: 10973. Data Updated: May 13, 2020 10:06:00 PM PDT.

COUNCIL PACKET



QUOTE

Quote ID: Q11504 Rev: 0

Quote Date: 5/22/2020

Quote Valid Until: 6/5/2020

Page 1 of 1

Phone: (515) 266-5189 Toll Free: (800) 373-2887 Fax: (515) 266-7878

Customer: 99999

Riverside, City of
60 Greene Street

Riverside, IA 52327

Contact:

Phone: (319) 648-3501

Fax:

Salesperson: Scott Odendahl

Make: Ram	Model: 2500	Year: 2020	Single/Dual:
Cab Type:	Wheelbase: 0	Cab-to-Axle: 56	VIN:

FURNISH AND INSTALL:

- 1 - Federal Signal LED Highlighter model 454101HL-25
- 1 - Go-Light Stryker LED remote controlled spotlight model 30514
- 1 - Weather Guard aluminum saddle box model 117-0-02
- 2 - Weather Guard aluminum lo-side box model 174-0-01
- 1 - Weather Guard cab protector model 1908
- 1 - Weather Guard cab protector mount kit model 1912-5-01
- 1 - Weather Guard warning light mount bracket model 1920
- 1 - Weather Guard spot light mounting bracket model 1919

Sub Total:	\$4,220.00
Discount:	
Sales Tax:	\$0.00
Grand Total:	\$4,220.00

Customer must fill out the information below before the order can be processed...

Accepted by:	
Date:	
P.O. Number:	

Terms are Due Upon Receipt unless prior credit arrangements are made at the time of order.
Please note if chassis is furnished, it is as a convenience and terms are Net Due on Receipt of Chassis.

COUNCIL PACKET



3941 Liberty Dr, Iowa City, Ia 52240
 Phone # 319-338-0991 Fax # 319-338-4749

Estimate

Date	Estimate #
5/27/2020	4685

Name / Address
CITY OF RIVERSIDE PO BOX 188 RIVERSIDE, IOWA 52327

LICENSE PLATE	MILEAGE/PO#	VEHICLE
		2020 RAM2500

Description	Qty	Rate	Total
FURNISH AND INSTALL: 1-FEDERAL SIGNAL LED HIGHLIGHTER MODEL 454101HL-25 1- GO-LIGHT STRYLER LED REMOTE CONTROLLED SPOTLIGHT MODEL 30514 1- WEATHER GUARD ALUMINUM SADDLE BOX MODEL 117-0-02 2- WEATHER GUARD ALUMINUM LO-SIDE BOX MODEL 174-0-01 1- WEATHER GUARD CAB PROTECTOR MODEL 1908 1- WEATHER GUARD CAB PROTECTOR MOUNT KIT MODEL 1912-5-01 1- WEATHER GUARD WARNING LIGHT MOUNT BRACKET MODEL 1920 1- WEATHER GUARD SPOT LIGHT MOUNTING BRACKET MODEL 1919		4,220.00	4,220.00

Estimate amount honored for 30-Days from date of estimate.

Subtotal	\$4,220.00
Sales Tax (0.0%)	\$0.00
Total	\$4,220.00

Signature _____

COUNCIL PACKET



P.O. Box 3265
Des Moines, IA 50316

Phone: (515) 266-5189 Toll Free: (800) 373-2887 Fax:(515) 266-7878

QUOTE

Quote ID: Q11505

Rev: 0

Quote Date: 5/26/2020

Quote Valid Until: 6/9/2020

Page 2 of 3

FURNISH AND INSTALL:

1 - 9'6" WESTERN STEEL FLARE-WING MULTI-POSITION V-PLOW (MODEL IUTMVP395)

ULTRAMOUNT 2 mounting system
TWO SEASON WARRANTY

Swivel bar design for more even cutting edge wear

Removable pockets for more ground clearance when plow is removed from truck

Pitch adjustment feature - allows pitch of the blade to be adjusted to compensate for uneven cutting edge wear

Straight Blade Width: 9'6"

Full Scoop width: 98", , full "V" width: 103", or fully angled width: 102"

Blade height: 31" at hinge - 39" at end

14 ga. steel moldboards with 4 vertical ribs per side

PRO PLUS type "power bar construction"

Trip edge design featuring 6 trip springs

Western blade guides

MVP PLUS hydraulic system

With hand-held "Cab Command" control

Low profile dual stud mount "NIGHTHAWK" composite halogen light kit

"Isolation Module" advanced snowplow light and electrical system improves system life and complies w/ OEM requirements

Double acting cylinders to aid back dragging

Steel top gap deflector

Formed cutting edge provides lower center gap coverage

ULTRA FINISH baked-on powder coat with new primer

SECURITY GUARD anti-theft system allows you to electronically lock the snowplow's hydraulic functions

FLEET FLEX multiplex wiring for true fleet interchangeability

OPTIONS INCLUDED IN PRICE:

Installed on customers truck including all necessary fluids, etc.

Pricing per state bid MA005-18177B (expires 3/9/21)

NET PRICE FOB DES MOINES \$6,578.28

OPTIONS NOT INCLUDED IN PRICE:

Cast skid shoes (43088)	ADD \$218.00
Deflector kit, 10" (41810)	ADD \$315.00
Deflector kit, 18" (41811)	ADD \$435.00
Back drag edge (44283-3)	ADD \$354.00
Curb guard kit (43885)	ADD \$253.00
Wing extension kit (43510-1)	ADD \$726.00
Blade stop kit (43082-1)	ADD \$162.00
LED headlights (72525)	ADD \$407.22
Cup holder control mount (82007)	ADD \$ 37.00

Customer must fill out the information below before the order can be processed...

Accepted by:	
Date:	
P.O. Number:	

* Terms are Due Upon Receipt unless prior credit arrangements are made at the time of order.



FUTURE LINE LLC
 550 60th Ave SW
 Cedar Rapids, IA 52404
 P:(319) 730-3800
 F:(319)-730-3805

COUNCIL PACKET

ESTIMATE

Date:
 INV # **S1-39910**

To :
CITY OF RIVERSIDE
 Account # :A18081
 CITY OF P.O. BOX 188 21 E. 1ST
 RIVERSIDE, IA, 52327

Ph# :(319) 648-3501



Sales Order No.

Qty.	Part Number	Description	Tech	Each	Total
Snow Plow Options					
1	WES-41810	RUBBER DEFLECTOR KIT - 10"		\$ 267.43	\$ 267.43
1	WES-43088	SHOE KIT		\$ 194.57	\$ 194.57
-	LAB-LABOR	LABOR		-	\$ 105.00
Snow Plow Options : Subtotal					\$ 567.00

Qty.	Part Number	Description	Tech	Each	Total
Western Snow Plow					
1	WES-74495	BLADE ASSY - 9-1/2' MVP3 MS		\$ 2335.66	\$ 2335.66
1	WES-74300-3	BIG BOX ASSY MVP3		\$ 2915.42	\$ 2915.42
1	WES-72525	LIGHT KIT, LED, COMPLETE		\$ 851.14	\$ 851.14
1	WES-33888	MOUNT KIT RAM UM #33888		\$ 498.86	\$ 498.86
1	WES-69892-1	HARNES KIT, 7 WIRE		\$ 216.00	\$ 216.00
1	WES-29070-1	MODULE 3 PORT - DRL/NON-DRL		\$ 125.14	\$ 125.14
1	WES-96500	MULTI-POSITION PLOW HH CONTROL		\$ 372.00	\$ 372.00
-	LAB-LABOR	LABOR		-	\$ 315.00
3	VDC-MOBIL ATF	UNIVERSAL ATF		\$ 13.09	\$ 39.27
Western Snow Plow : Subtotal					\$ 7668.49

NOTES : 319-325-9287
 brian@cityofriversideiowa.com
 Verify Truck Before Ordering

Signature : _____ **Date** _____

ESTIMATE / PREVIEW ONLY - NOT VALID FOR WARRANTY

There is a restocking fee of 25% Terms are net 30 anything past due will be charged a finance fee of 1.5%

Vehicle Information

Vehicle :
 License # :
 Miles In :
 Miles Out :
 V.I.N. :
 Unit # :

DEPARTMENT	SALE
Labor	\$ 420.00
Parts	\$ 7815.49
Fluids/Supplies	\$ 21.00
SUB TOTAL	\$ 8256.49
SALES TAX	\$ 0.00
ESTIMATE AMOUNT	\$ 8256.49

COUNCIL PACKET



3941 Liberty Dr, Iowa City, Ia 52240
 Phone # 319-338-0991 Fax # 319-338-4749

Estimate

Date	Estimate #
5/27/2020	4653

Name / Address
CITY OF RIVERSIDE PO BOX 188 RIVERSIDE, IOWA 52327

LICENSE PLATE	MILEAGE/PO#	VEHICLE

Description	Qty	Rate	Total
9-6 MVP3 WESTERN PLOW	1	6,523.28	6,523.28
MUNICIPAL DISCOUNT		-495.00	-495.00
SUBTOTAL PARTS			6,028.28
ASSEMBLY & INSTALLATION OF A 9'6" WESTERN MVP3 SNOWPLOW.	1	550.00	550.00
SUBTOTAL LABOR			550.00
SUBTOTAL PARTS AND LABOR			6,578.28
NO OPTIONS INCLUDED			

Estimate amount honored for 30-Days from date of estimate.

Subtotal	\$6,578.28
Sales Tax (0.0%)	\$0.00
Total	\$6,578.28

Signature _____

QUANTITY BUCKET



LUVERNE GRIP STEP RUNNING BOARDS

Real Truck Savings Event! - Best Prices Guaranteed. Chat NOW For Unbeatable Deals!



LIST PRICE: \$476.35

OUR PRICE: **\$415.11**



FREE SHIPPING



Best Price Guaranteed
855-404-9677

RATING: ★★★★★ (24)

Part #: LUV-415060-401231

Frame Mount

QTY: 1

ADD TO CART

As low as \$37/mo with **affirm**. [Prequalify now](#)

Related Products



Coverking Neosupreme Seat Covers

From: \$169.99

★★★★★ 262



Fia Leather Lite Seat Covers

From: \$242.00

★★★★★ 182



15% OFF

CalTrend NeoSupreme Seat Covers

Sale: \$73.06

★★★★★ 256



Saddler Ballistic Covers

From: \$16

★★★★★

4.3★★★★★
Google
Customer Reviews

COUNCIL PACKET

Estimate for wall removal and rebuild in City Hall.

Counter tops	345.33
glass enclosure	2634.83
electric work	1500.00
drywall, mud , tape ,misc.	300.00
door hardware	600.00
ceiling tile repair	300.00
total	\$ 5,680.16

This would probably take about 40 man hours to do.



IOWA30325518

CASHIER:
PLEASE
STAPLE
RECEIPT
TO BACK

SPECIAL ORDER CONTRACT
GUEST COPY



STORE # 3091 PHONE: 3193589708
2605 Naples Ave FAX: 3193589605
Iowa City, IA 52240

GUEST NAME-ADDRESS-PHONE
Stuelke, Jay 104 Cherry Ln Riverside, IA 52327-2200 Phone: 319-331-3467

- | IMPORTANT |
|---|
| <ol style="list-style-type: none"> 1. Verify quoted product and quantity 2. Product will be ordered upon payment 3. Track order on Menards.com 4. Pick up order within 7 days of arrival at store (N/A - Deliveries and Pickup at Plant) 5. Retain receipt |

THANK YOU!

EST. DELIVERY DATE NOT BINDING ON MENARDS	
INC. BASED ON PROMISES BY OTHERS 05-28-2020	
SOLD BY	ORDER DATE
BRANDON H	05-14-2020

QTY	ORDERED	DESCRIPTION	SKU	UNIT PRICE	EXTENDED PRICE
Consolidated Footage / Color / Description					
10	FT.	Laminate Aurora 15" Top Color: 9497-58, Silver Quartzite	4860142	\$28.99	\$289.90
Design 1					
51 5/8"	IN.	Aurora 15" Top Color:9497-58, Silver Quartzite	4860142		
1	EA.	Left Island End Cap Applied	4861041	\$10.99	\$10.99
5	FT.	Back Profiled Edge	4861041	\$10.99	\$10.99
1	EA.	Right Island End Cap Applied	4861041	\$10.99	\$10.99
51 5/8"	IN.	Aurora 15" Top Color:9497-58, Silver Quartzite	4860142		
1	EA.	Left Island End Cap Applied	4861041	\$10.99	\$10.99
5	FT.	Back Profiled Edge	4861041	\$10.99	\$10.99
1	EA.	Right Island End Cap Applied	4861041	\$10.99	\$10.99
Accessories					
0	EA.	Design Template, Ship Standard, ***DECLINED***	4869701	\$34.95	

This is a quote valid today. This quote becomes an order upon payment and a valid Menards receipt is attached.

READ THIS CONTRACT CAREFULLY. The terms and conditions set forth in this document are a complete and final expression of the parties. The contract cannot be altered except by written instrument explicitly signed and executed by the General Manager. Any and all claims under this contract must be brought within one year of the purchase. **Special order product** may be refunded at Menards sole discretion with a 25% restocking fee. Purchaser is responsible for providing to Menards all measurements, sizes, and colors stated above. Purchaser's exclusive remedy, if any product is defective or fails to conform to the terms of the contract, is replacement of the product. All defects and non-conformities must be reported to Menards within 3 days of receiving the product. Purchaser understands that all product is sold **AS IS** and the manufacturer's warranty, if any, is controlling. **MENARDS MAKES NO WARRANTIES, EXPRESS OR IMPLIED AS TO THE MERCHANTABILITY OR FITNESS FOR A PARTICULAR PURPOSE OF THE PRODUCT.** There are no representations that the products listed herein meet local, state, or federal code requirements. Menards liability shall not exceed the purchase price of the products sold. **MENARDS SHALL NOT BE LIABLE FOR ANY SPECIAL, INCIDENTAL, OR CONSEQUENTIAL DAMAGES.** Menards agrees to email Purchaser when the product is available for pick-up. If Purchaser fails to provide an email address, it is Purchaser's responsibility to check the status of the order by visiting Menards.com. If Purchaser refuses or fails to pick up the product within 15 days from date of its availability, Menards may liquidate the product and shall be entitled to 25% restocking fee. Menards may withhold any payment received as partial satisfaction. Purchaser agrees that Menards is not liable if the vendor, which supplies the product on this contract, fails to perform. Purchaser agrees that any and all controversies or claims arising out of or relating to this contract, or the breach thereof, shall be settled by binding arbitration administered by the American Arbitration Association under its applicable Consumer or Commercial Arbitration Rules. Purchaser agrees that all arbitrators selected shall be attorneys. This provision shall supersede any contrary rule or provision of the forum state.
YOUR PURCHASE OF THE PRODUCT ON THIS CONTRACT CONSTITUTES YOUR AGREEMENT TO ALL TERMS AND CONDITIONS STATED ABOVE.

SUB-TOTAL: \$345.33
SHIPPING CHARGES:
PRE-TAX TOTAL: \$345.33

VENDOR: **MIDWEST COUNTERTOPS**

For the most accurate and up-to-date status of your order, please use the Order Tracker at **www.menards.com**

If this is a partial pickup, please verify all quantities/items being signed for. Menards is not responsible for shortages after leaving the yard.



COUNCIL PACKET

Estimate #60796



Billing Address
 CITY OF RIVERSIDE
 60 Greene Street
 Riverside IA 52327 United States
 BECKY@CITYOFRIVERSIDEIO.
 +1 319-331-3467
 +1 319-331-3467
 +1 319-648-3501
 +1 319-331-3467

Service Address
 CITY OF RIVERSIDE
 60 Greene Street
 Riverside IA 52327 United States
 BECKY@CITYOFRIVERSIDEIO.
 +1 319-331-3467
 +1 319-331-3467
 +1 319-648-3501
 +1 319-331-3467

Send Payment To
 MGSI, Ltd
 122 Lafayette St
 Iowa City IA 52240
 3193512261
 info@mgsiglass.com

Sent	05/14/20
Total	\$2,634.83
Payments	\$0.00
Balance	\$2,634.83

Contact: JAY STUELKE
 319-331-3467

Contact: JAY STUELKE
 319-331-3467

Scope of Work

FURNISH AND INSTALL (2) RECEPTION DESK STATIONARY WINDOWS WITH ENVELOPE SLOT & SPEAK THRU.

Charges

Item	Description	Unit Cost	Tax	Quantity	Line Total
4007- Comm Service	RECEPTION GLASS - -WE PROPOSE TO UN-INSTALL CURRENT BY-PASS STYLMARK WINDOWS IN RECEPTION AREA AND FURNISH AND INSTALL SAFETY TEMPERED GLASS SCREENS WITH ENVELOPE SLOTS INTO (2) OPENINGS. ROUGH SIZES PROVIDED VIA PHONE CALL. -INSTALLATION WILL INCLUDE: <ul style="list-style-type: none"> • REMOVING CURRENT STYLMARK ASSEMBLIES (HOLES IN DRYWALL/PAINT TO BE COMPLETED BY SOMEONE ELSE IF NEEDED) PER. • LAYOUT NEW STAINLESS STEEL CLAMP SYSTEM AND INSTALL CLAMPS TO WALL, CEILING & COUNTER TOP PER. • INSTALL 1/4" CLEAR SAFETY GLASS WITH POLISHED EDGES INTO CLAMPING SYSTEM PER. • DISPOSING OF OLD SYSTEM -GLASS SIZE: (2) 49 7/8" X 36 1/2" X 1/4" CLEAR TEMPERED WITH CUSTOM FABRICATION FINGER SLOTS AND ENVELOPE SLOTS & POLISHED EDGES. *PLEASE NOTE: THIS IS A ROUGH ESTIMATE AND CAN CHANGE DEPENDING ON CONDITIONS OF OPENING AND SIZES. MGSI WILL NEED TO CONFIRM SIZES BY MEASURING OPENING IN PERSON BEFORE ORDERING GLASS. CORRECTIONS, IF ANY, WILL BE MADE TO THIS ESTIMATE AT THAT TIME *	\$2,634.83	✓	1.0	\$2,634.83

PAYMENT TERMS:

NET 10

IF THERE ARE ANY QUESTIONS, FEEL FREE TO CALL OR EMAIL.

THANK YOU FOR THE OPPORTUNITY TO BID THIS JOB FOR YOU

CONTACT INFORMATION:

ESTIMATOR: SHAUN CHRISTOPHERSON

EMAIL: SHAUN@MGSIGLASS.COM

DIRECT: 319-519-6703

COUNCIL PACKET

MAIN OFFICE: 319-351-2261

Subtotal	\$2,634.83
Tax	\$0.00
Total	\$2,634.83

Payments

Date	Type	Amount
No payments		

Notes

Lead times vary and will be provided at time of order.

EXCLUSIONS

Openings, opening modifications, overtime or shift work unless specified, architectural testing, break metal trim or flashings, engineering stamps or calculations, any item not specifically called out for. Final cleaning by others. Standard 1 year craftsmanship warranty. Material warranties are provided by manufacturers and subject to terms by manufacturer, which are available upon request.

Terms

All payments are due within the terms outlined above. If terms are not listed, default terms are NET 10 from invoice. Accounts with existing credit shall default to terms per approved credit agreement with MGSI.

Any amount not paid beyond accepted term will incur a late payment penalty at 1.5% interest compounded monthly (18% APY).

MGSI reserves the right to revoke or change credit limits and payment terms at any time.

Accounts not paid in full beyond 90 days without written payment schedule shall be reported to a Credit Bureau.

Persons or companies furnishing labor or materials for the improvement of real property may enforce a lien upon the improved property if they are not paid for their contributions, even if the parties have no direct contractual relationship with the owner. The mechanics' notice and lien registry internet site provides a listing of all persons or companies furnishing labor or materials who have posted a lien or who may post a lien upon the improved property. If the person or company has posted its notice or lien to the mechanics' notice and lien registry internet site, you may be required to pay the person or company even if you have paid the general contractor the full amount due. Therefore, check the mechanics' notice and lien registry internet site for information about the property including persons or companies furnishing labor or materials before paying your general contractor. In addition, when making payment to your general contractor, it is important to obtain lien waivers from your general contractor and from persons or companies registered as furnishing labor or materials to your property. The information in the mechanics' notice and lien registry is posted on the internet site of the mechanics' notice and lien registry.

MNLR Internet Web site address (sos.iowa.gov/MNLR) and MNLR toll-free telephone number (1-888-767-8683).

The requirements of Iowa Code chapter 572 which are outlined on this page apply only to residential construction projects.

Additional Notes

Date	Name	Note
05/14/20	SHAUN CHRISTOPHERSON	TRO PROVIDED ON THE PHONE FOR ROUGH BID IS: 51 5/8" X 38 1/4"

Signatures

Name	Signature	Reason	Requested	Signed	Document
------	-----------	--------	-----------	--------	----------

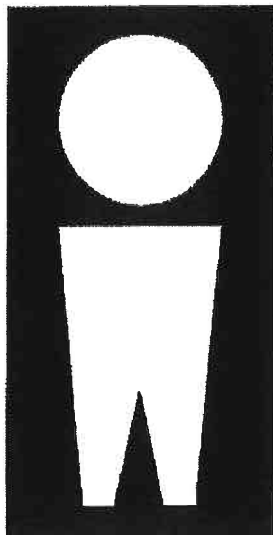

Quotation

Date: 05/18/20 ATTN; Jay

TO; City of Riverside

JOB; City Hall

LOCATION; Riverside, IA

ADDENDUM(S); 0

QUOTE EXPIRES; 30 DAYS

.00	Description	Price
	1ea. Exit Device with Lockable Lever Trim "Sargent" 3828 C-LL EN/26D	
	1ea. Latchbolt Filler Plate	
	1ea. Frame Strike Filler Plate	
	Verify Keyway to Match Building System	
	Materials Only	
	TOTAL.....(No Tax Included)...	\$ 565.00
	Installation.....(No Tax Included)....	\$ 380.00

CONDITIONS: Unless otherwise specifically covered above, the following apply to this Agreement

1) N/A	5) Preparation for concealed hardware not included.
2) We do include cylinders for aluminum doors.	6) All orders subject to approval of credit by Doors, Inc.
3) Steel doors and frames to have standard shop finish	7) <input checked="" type="checkbox"/> We do not include Iowa Sales Tax.
4) Door and frames to be reinforced for surface hardware, but not Drilled and tapped.	8) <input checked="" type="checkbox"/> Material only
	9) <input checked="" type="checkbox"/> F.O.B. Job Site

Terms: Net 30 days. No retain-age allowed.

Take off By Doors, Inc.:

Take off By Others:

Accepted By: _____
 \$380.00
 Company: _____
 Date: _____

Respectfully Submitted
 Doors, Incorporated
 By: Paul O Eliason
 Paul Eliason peliason@doorsinciowa.com
 Fax: 319-354-0175

3828 Rim Type
30 Series Exit Device

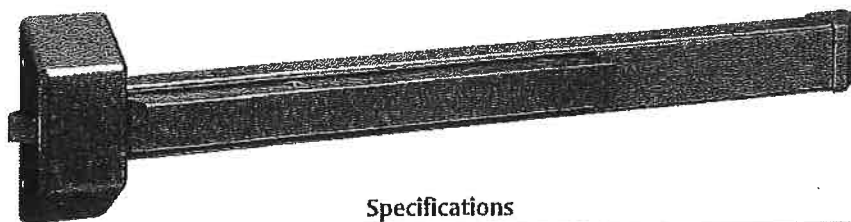

Specifications

For Doors	1-3/4" (44) thick standard. 4-1/2" (114mm) minimum stile width required for single or double door application using standard 649 strike
Outside Trim & Thumb Piece Trims	28 Series Lever & Rose trims, GTB/HTB Pulls & Plates OB Knob trims
Mounting	Furnished standard with wood and machine screws Available with through bolts and mortise nuts
Cover	Steel
Chassis	Nonferrous alloy
Rail Assembly	Roll formed steel
End Cap	Steel
Hand	Non handed
Latchbolt	Stainless steel 3/4" (19mm) throw
Strike	649 packed standard
Dogging Feature	Allen-type key furnished standard (non fire rated devices only)
Fire Exit Hardware	See chart Page 1
Finish	EB, ED, EN, EP, EAB

The 3828 Multi-function Rim Exit Device is the perfect stocking device.

- 7 functions determined by trim selected
- Device & trim sold separately; easy to mix and match
- 4 available trim designs

Order as an 3828 followed by rail size and finish

649 Strike

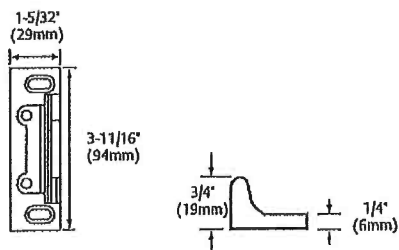

- Surface applied
- Standard & Fire Rated
- Strikes are black nylon coated

Minimum Stile Requirements

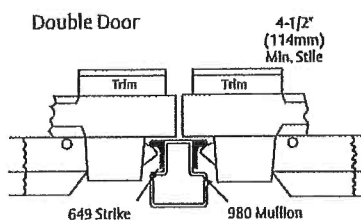

Minimum Stile Requirements

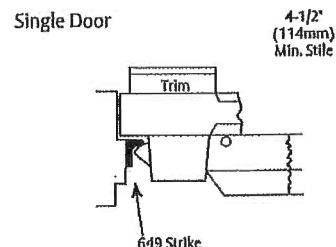

Copyright © 1999, 2001, 2004, 2008-2013, Sargent Manufacturing Company, an ASSA ABLOY Group company. All rights reserved. Reproduction in whole or in part without the express written permission of Sargent Manufacturing Company is prohibited.

30 Series Trims
30 Series Exit Device

The trim function determines the function of the exit device. All 28 Series trims work with all 30 Series Exit Devices, except where noted.
Note: All trims and exit devices are ordered and packaged separately.

28 Series Lever & Rose Trim for 3727/3828 Series Exit Devices



Lever & Rose Trim

- For 1-3/4" (44mm) doors only
- Functions available for 04, 06, 10, 13 & 15
- Not handed
- Finishes: 03, 04, 10, 10B, 10BE, 20D & 26D
- Lever designs available: "L", "B", "P"

To order specify 28 followed by the function (K, N, D, C or L), the rose (L), the lever (L, B or P) and finish

Example: 28-K-LL x 26D

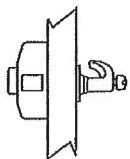

28-K-LL
Night Latch

Key in lever retracts latchbolt.

04 Function
For 3828 only
(ANSI 03)

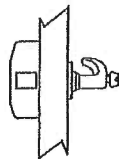

28-N-LL
Night Latch

Lever operates only when key is in cylinder and turned.

06 Function
(ANSI 09)

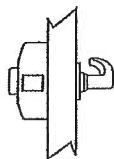

28-D-LL
Dummy

Lever rigid at all times & no outside function.

10 Function
(ANSI 02)

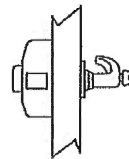

28-C-LL
Entrance

Key in lever locks or unlocks lever.

13 Function
(ANSI 08)

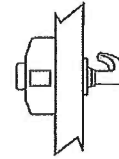

28-L-LL
Passage

Latchbolt operated by lever.

No Cylinder
15 Function
(ANSI 14)

28 Series GTB/HTB Pulls & Plates for 3727/3828 Series Exit Devices

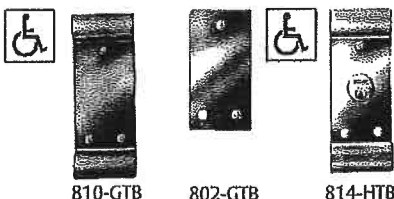

810-GTB

802-GTB

814-HTB

- For 1-3/4" (44mm) doors standard
- Through-bolted with 3 mortise nuts
- Pulls project 1-1/2" (38mm) from door face
- GTB Design trim will cover a 161 cutout
- Trim ordered separately.
- Finishes: EN, EB, ED, EP & EAB
- For cylinder operation only with no trim (Specify 3828 x 34 rim cylinder x Finish)

To order specify: trim design and finish

Example: 814-HTB x EN

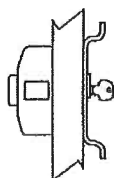

814-HTB
Night Latch

Outside by pull and key.

04 Function
(ANSI 03)

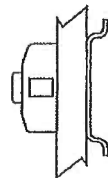

810-GTB
Exit Only with Pull

Outside pull when push bar is locked down.

10 Function
(ANSI 02)

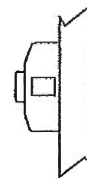

802-GTB
Exit Only

Blank plate to cover 161 cutout.

10 Function
(ANSI 01)

28 Series Thumbpiece Trim for 3727/3828 Series Exit Devices

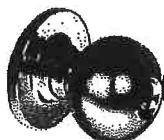

- For 1-3/4" (44mm) doors only
- Functions available for 04, 13 and 15
- Non-handed
- Finishes: 03, 04, 10, 10B, 10BE, 20D & 26D

To order specify 28 followed by the function (K, C or L), the rose (O), the knob (B) and finish

Example: 28-K-OB x 26D

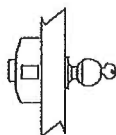

28-K-OB
Night Latch

Key in knob retracts latchbolt.

3828 only
04 Function
(ANSI 03)

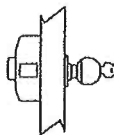

28-C-OB
Entrance

Key In knob locks or unlocks knob.

13 Function
(ANSI 08)

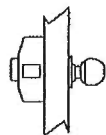

28-L-OB
Passage

Latchbolts operated by knob.

No Cylinder
15 Function
(ANSI 14)



- Finishes: EN, EB, ED, EP & EAB
- *1 3/4" Door Only

866-TP

Key locks or unlocks thumbpiece.
(63)

814-TP

Key retracts latchbolt.
(3828 ONLY)
(04)

828-TP

Thumbpiece always operable.
(28)

810-TP

Dummy trim.
(10)

To order specify: trim design and finish
Example: 866-TP x EN

Copyright © 1989, 2001, 2004, 2008-2013, Sargent Manufacturing Company, an ASSA ABLOY Group company. All rights reserved. Reproduction in whole or in part without the express written permission of Sargent Manufacturing Company is prohibited.

9012657 10/11/13

COUNCIL PACKET

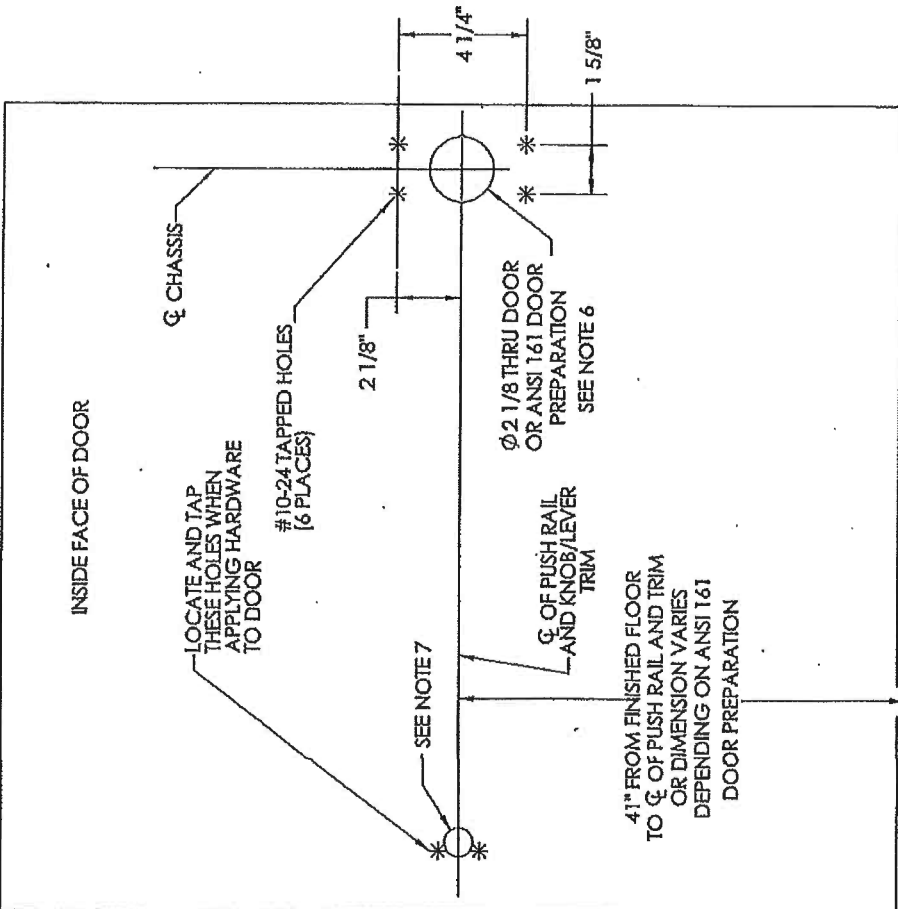

- 7 — SEE TEMPLATE 4569 FOR ELECTROLYNX DETAILS WHEN NEEDED.
- 6 — FOR 28- LEVER TRIM SEE TEMPLATE 4485, IF 88- LEVER TRIM IS USED (DOORS OVER 1 3/4" THICK). SEE TEMPLATE 4428 FOR TRIM DETAILS.
- 5 — SURFACE OF DOOR WHERE EXIT DEVICE IS TO BE APPLIED MUST BE FLUSH.
- 4 — SEE MASTER SHEET No. 4019 FOR AREAS REQUIRING REINFORCEMENTS.
- 3 — SEE STRIKE TEMPLATE FOR MOUNTING LOCATION OF STRIKE.
- 2 — FOR 881 MONIFOR STRIKE SEE TEMPLATE # 4386
- 1 — WE RECOMMEND THAT ALL TAPPED HOLES BE DRILLED & TAPPED IN FIELD.
- 1 — TOLERANCE ON ALL DIMENSIONS ±1/32".

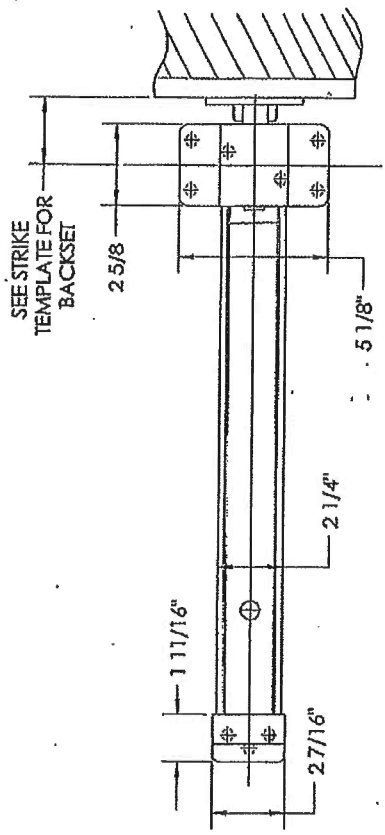

12-2828 SERIES

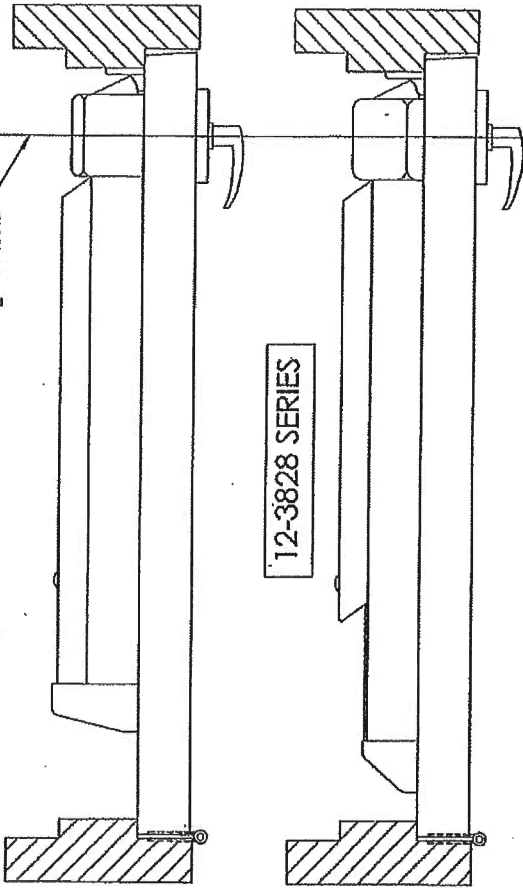

SARGENT® Manufacturing Company 100 Sargent Drive New Haven, CT 06511	
DOOR MANUFACTURERS TEMPLATE 12-2828 & 12-3828 WITH KNOB OR LEVER TRIM	RELEASE DATE 31 JAN 06
TEMPLATE NO. 4304 F	

COUNCIL PACKET

REQUIRED BACKSET		MINIMUM STILE REQUIRED WITH VARIOUS TRIMS		
EXIT DEVICE	BACKSET	ET, STS	PTB, PSB	FLW/FSW FLL/FSL MAL/MSL
2800, 3800, 5100 5800, 8800, 9800 P800	2 1/4"	3 1/2"	4"	3 9/16"
8600, 6500	1 1/2"	2 1/2"	3 1/4"	2 13/16"

1. TOLERANCES: FRACTIONAL $\pm 1/64$ ", DECIMAL $\pm .015$.
2. SEE APPROPRIATE DOOR MANUFACTURERS TEMPLATE TO MOUNT EXIT DEVICE.
3. IF DOOR SILENCERS ARE USED ON THE FRAME, DECREASE THIS DIMENSION BY SILENCER HEIGHT.
4. IF "GLASS BEAD" SHIMS ARE USED, INCREASE THIS DIMENSION BY SHIM HEIGHT (1/8" PER SHIM USED).
5. AFTER STRIKE IS INSTALLED AND ADJUSTED, TWO CENTER HOLES ARE TO BE DRILLED AND TAPPED FOR # 10-24 ROUND HEAD MACHINE SCREWS.
6. MINIMUM STILE IS EFFECTED BY OUTSIDE TRIM, SEE TABLE.

SARGENT Manufacturing Company <small>100 Sargol Blvd New Haven, CT 06511</small>	RELEASE DATE JUN 14 07
DOOR MANUFACTURERS TEMPLATE: 649 STRIKE SINGLE DOOR APPLICATIONS	TEMPLATE NO. 4004 K

COUNCIL PACKET

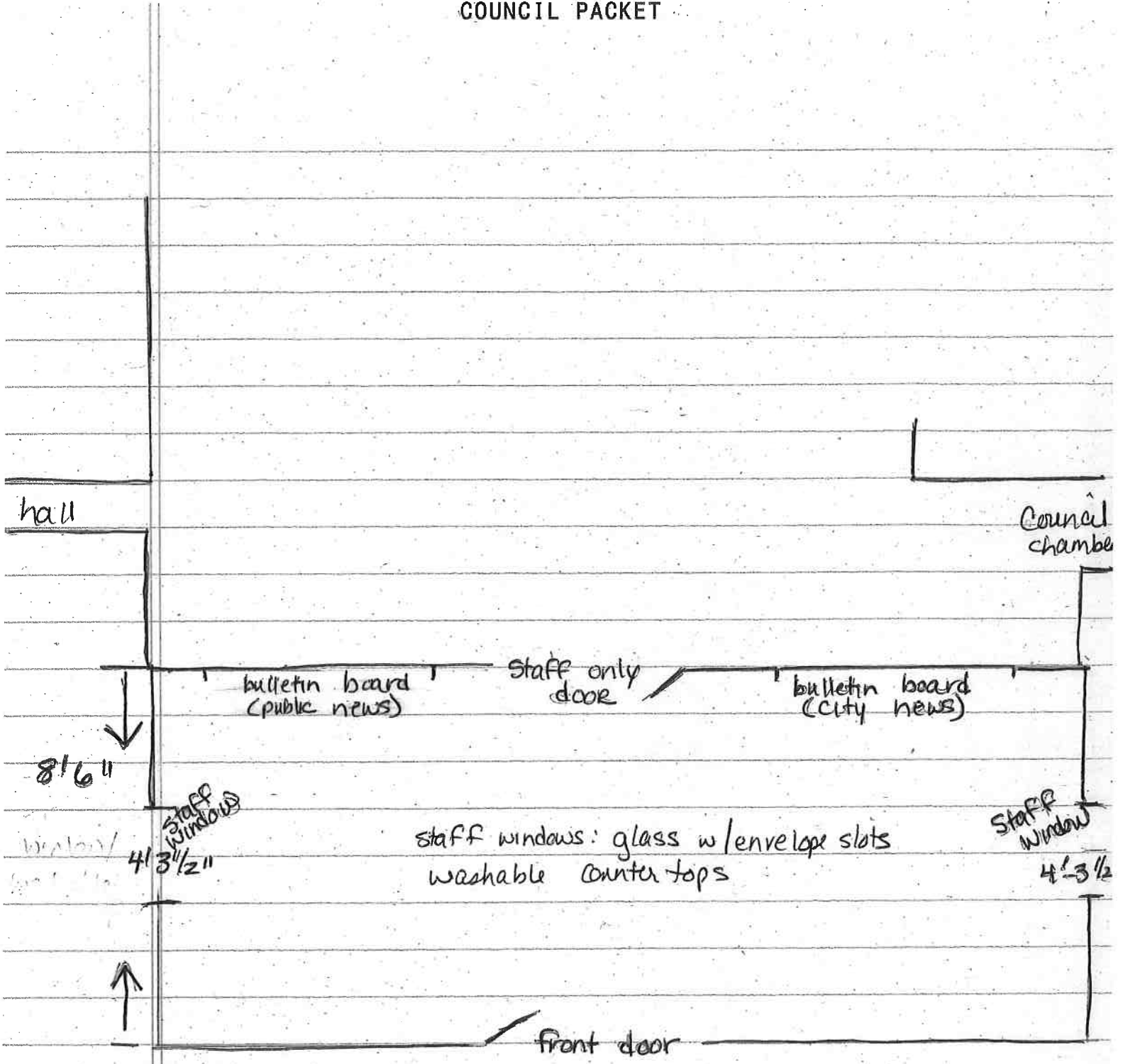

Not to scale

COUNCIL PACKET

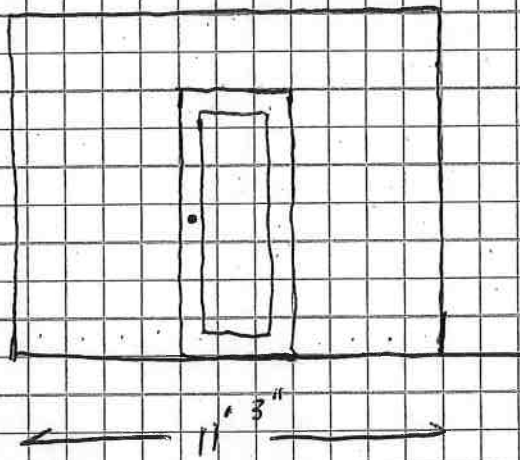

COUNCIL PACKET

Considering the status of the COVID-19 Pandemic, City Hall will be taking the following precautions for the safety and well being of the public, City staff and PW staff:

- Anyone who needs to come into City Hall – we recommend that you call in first.
- Essential business only in City Hall – No Socializing Allowed.
- **We strongly encourage all payments to still be made by using our drop box, calling in and paying with credit/debit card or by using our website [riversideiowa.gov](https://www.riversideiowa.gov).**
- If you are sick (fever, cough, a cold), do not come into City Hall.
- If you have been exposed to COVID-19, do not come into City Hall.
- Only one (1) person per family will be allowed in City Hall.
- Only one (1) person at the counter at any given time.
- No children allowed in City Hall.
- Restrooms are closed to the Public.
- Entrance and exit for the public will be through the east door of City Hall.
- Masks are recommended.
- Staff will wipe down counters after each customer leaves.
- If you have any questions, you can call the City offices at 319-648-3501

We urge the Riverside Community to be mindful of your surroundings and to use common sense and best practices regarding the Coronavirus.

We realize this is not an ideal situation, but we appreciate and thank you for your understanding, patience, and cooperation.

COUNCIL PACKET

Estimate

Custom Tree Service
 2750 Highway 22
 Riverside, IA 52327
 319-591-3375
 customtreeserviceia@gmail.com



ADDRESS
City of Riverside 61 Green Street Riverside, IA 52327 USA

ESTIMATE #	DATE
1031	05/05/2020

DATE	DESCRIPTION	QTY	RATE	AMOUNT
05/05/2020	Removal of broken Birch Tree on Washburn Street	1	150.00	150.00
05/05/2020	Grinding and clean-up of Birch stump	1	100.00	100.00
05/05/2020	Removal of medium sized Ash tree on Washburn Street	1	550.00	550.00
05/05/2020	Grinding and removal of wood chips	1	125.00	125.00
05/05/2020	Removal of Heaven Tree Clump on Main Street (Highway 22)	1	350.00	350.00
05/05/2020	Grinding of Heaven Tree Stump on main street	1	200.00	200.00

TOTAL **\$1,475.00**

Accepted By

Accepted Date

COUNCIL PACKET



City of Riverside Downtown Business District Incentive Program

Program Objective

Provide financial assistance to commercial entities for the redevelopment or remediation of underutilized buildings.

Project Intent

- make a positive, high-impact visual improvement to commercial buildings
- provide an overall enhanced image
- maintain the structural integrity of the downtown historic buildings
- increase property values
- demonstrate public/private sector investment
- provide a significant positive impact on the community

Definitions

- **Building:** A structure used or intended to be used for commercial purposes. This grant is not available for residential purposes.
- **Underutilized building:** A building that is vacant or mostly vacant, is blighted or severely deteriorated, contains potential safety hazards including structural instability, code noncompliance, hazardous materials or generally unsafe or hazardous conditions.

Available Assistance

The City of Riverside shall administer the fund in a manner to make grant moneys available each fiscal year when funding is available and established by City Budget and Resolution.

Maximum grant amount per applicant per year shall not exceed \$10,000.00. Monies awarded will be on reimbursement basis, with 50% of expenses reimbursed to the maximum amount allowed per year.

Eligibility Requirements

- Available to property or building owners only
- Must be in the business district
- Mixed-use buildings: Only the Commercial portion of the building is eligible
- Must meet the definition of building

COUNCIL PACKET

- Must meet the definition of underutilized
- Work must be performed by a licensed contractor

Eligible Improvements

- Permanent commercial exterior improvements
- Compliance with ADA for commercial properties
- Installation, repair or replacement of exterior exit doors
- Repair and/or rebuilding of exterior walls, including sealing and tuck pointing
- Repair or replacement of frames, sills, glazing, glass and/or installation of new windows
- Installation, repair, or replacement of exterior lighting
- Repair, replacement or purchase of signs-preference of use of local business for sign construction
- Repair, replacement or addition of exterior shutters, awnings, and/or canopies
- Roof installation, repair or replacement

Ineligible Improvements

- Interior remodeling improvements
- Projects started, in process or completed prior to application for the grant
- Projects where other grant funding has been received
- Labor provided by the applicant

Grant Forms/Application Period

- Grant forms will be available at City Hall and on the city website.
- Grant cycle will be July 1 through June 30 of each year
- Completed applications need to be received by at city hall each year by June 1st to be considered for the next grant cycle. Draft applications are strongly encouraged and can be submitted as early as February 1st. A completed application must include:
 - Application form with signatures of applicant and builder owner if different.
 - Formal drawings/plans for the project.
 - Photos of the project area.
 - Itemized budget that includes a complete list of projected expenses listing dollars applied for.
 - Bids/estimates from contractors.
 - Property owners estimated financial contribution. (Cannot use grant proceeds from other grants as financial contribution)
- Grants are awarded on a FY basis, with money available for successful grants following July 1st. Projects must be completed with rebate request forms with the appropriate supporting documentation submitted by May 31st of the grant cycle.

COUNCIL PACKET

- The Grant Review Committee will review, score and recommend applications for approval to the City Council for approval. Scoring may be based on:
 - Threats to the survival of the structure
 - Importance of the structure to the overall goals
 - Cost effectiveness of the proposed work
 - Time required to complete the project

The applicant is responsible for obtaining any necessary building permits prior to beginning the project and will be responsible for complying with all ordinances and laws. Any changes to the original approved project must be submitted to city hall for review of eligibility. Failure to do so may disqualify a successful grantee.

When the project is complete, the applicant will submit to the City copies of all bills including proof of payment. The City will determine whether the overall project met program guidelines. If all requirements have been met the City will issue payments to the applicant within 30 days of approval. Partial payments will not be made prior to completion and review and approval of the finished project.

Grant Application Checklist:

- I have read the information provided with the Grant Application for the Business District Incentive Program.
- Formal drawings/plans for the project are included with the application.
- Photos of the project area are included with the application.
- An itemized budget with projected expenses is included with the application.
- Bids/estimates from contractors are included with the application.
- Property owners estimated financial contribution is included with the application.
- The application has been signed and dated by the applicant.
- Any special circumstances that may affect the safety of the building have been included with the application.

COUNCIL PACKET



Trek
"Where the Best Begins"

CITY OF RIVERSIDE BUSINESS DISTRICT GRANT APPLICATION

Applicant Name: _____ Phone Number: _____

Property Address: _____

Type of Business: _____

Please describe in detail the project you are requesting funding for. Attach all supporting documents including formal drawings/plans for the project, photos of the project area, itemized budget listing projected expense, grant dollars applied for, bid/estimates from contractors, and property owner's estimated financial contribution

Briefly explain these improvements to your building will enhance the business district and the reason for the improvements.

If the grant is awarded, will this grant complete the project or will additional work need to be done? Please explain.

Total Project Cost: \$ _____

Total Amount Requested from the City: \$ _____

I understand the City of Riverside Business District Incentive Program must be used in the manner described in the attached requirements and that funding is contingent on both the application being approved by the City Council and funding being available.

Applicant Signature: _____ Date: _____

COUNCIL PACKET

FOR CITY USE ONLY

Date Draft Application Received (if applicable): _____

Date Grant Application Received: _____

Date Reviewed by Grant Committee: _____

Responses from Grant Committee: _____

Recommendation for Approval by Grant Committee: _____ Yes _____ No

Council Decision: _____ Yes _____ No

Comments:

COUNCIL PACKET

Employee Review Plan:

- Each employee complete a personal assessment form-6/1
- City Administrator will complete an assessment form for each employee-6/1
- Each employee meet with City Administrator to review responses and discuss. Review goals made last year and determine what has been completed and response on those not completed-week of 6/1
- Take review answers to Employee Committee for further review and discuss salary increases-week of 6/8
- Employee Committee presents salary increases for entire council and requests approval-6/18

COUNCIL PACKET

City of Riverside
Administrator Report
May 18, 2020

- Staff is holding daily meetings from 8:00-8:15, 8:30 to discuss the tasks for the day and any updates on projects. We practice social distancing.
- Washington zoom meetings for updates Wednesday's
- Governor's Press Conference daily at 11:00
- Phone meetings with council members
- New wi-fi equipment and firewall installed 5/19
- Ambulance meeting 5/20
- Ash/Tupelo walkthrough 5/20
- WEDG Zoom meeting 5/20
- Heritage Agency on Aging zoom meeting 5/27
- Sale of property to Copper Ridge 5/28
- Ambulance meeting 5/28
- Phone calls with attorney on Northern Heights, contracts
- Working on employee annual review
- Payroll review
- Hall Park possible expansion
- Engie-DNR permitting
- Opening of city hall, parks, playgrounds, pavilions
- Agenda prep

Public Works:

- Mowed parks, ball diamonds
- Don watering flowers
- Built dry erase board for CA
- Sanitized trucks and shop
- Helped with City Hall clean out
- Worked on bid for City Hall wall
- Discussion with resident on drainage issue
- Cleaned out intake on 4th St
- Took items to landfill
- Worked on pricing on trucks
- Greased mowers
- Weed whacked shop, parks
- Checked on fuel leak repair on 06 truck
- Sprayed weeds
- Lowered flags per Governor
- 4th Street meeting
- Picked up parts for vehicles
- Filled in and seeded sidewalk at water tower
- Hauled dirt to Galileo
- Worked with contractor on fire extinguisher check, new for apartment
- Prepared apartment for renting-have new tenant

COUNCIL PACKET

- Added water to Veteran's Park waterfall
- Discussed off street parking for rental house